

The Valla 120E pick & carry crane is just as much at home lifting indoors as outdoors.

Its non-marking tyres and articulating rear axle allow it to move around congested clean environment with ease

The crane delivers an impressive maximum safe working load of 12t and is designed to simplify lifting duties in industrial environments, improving safety, productivity and sustainability.



12,000kg Max Lifting Capacity



CPCS - A66 Compact Crane (B)
+ Product Familiarisation



Technical Specifications

Max Lifting Capacity	12,000kg
Max Working Height	9.8m
Max Working Radius	7.6m
Capacity @ Max Height	3,400kg
Capacity @ Max Radius	1,800kg
Power Source	Batteries/Diesel
Height	2420mm
Length	3975mm
Width	2100mm
Total Machine Weight	14,000kg

Optional Accessories

- Non-marking tyres
- Hydraulic winch & hook block
- Fly jib
- Custom paint colour
- Enclosed cabin
- Forks



Fly jib (optional)



Articulated rear axle enables the Valla 120 to be manoeuvred into congested work areas.

Dimensions

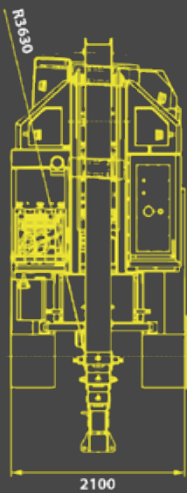
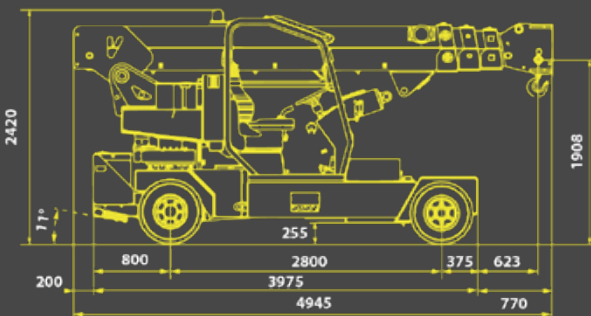

Working envelope

