

Valla
MANITEX

0,65

30°

HIRD
SALES



V 6 0 R
RADIOCOMANDATA

SCHEMA PRODOTTO
Product details / Détails du produit
Produktdetails/ Detalles de producto

V 6 0 R

INFORMAZIONI TECNICHE

Technical information / Informations techniques

Technische information / Información técnica



PORTATA MASSIMA

Max payload / Capacité maxi
Max Tragfähigkeit / Max capacidad

6.000 kg

PESO TOTALE

Total weight / Poids total
Gesamtgewicht / Peso total

5.800 kg

DIMENSIONI

Dimensions / Dimensions
Abmessungen / Dimensiones

2.750 x 1.180 x 1.680 mm

ANTERIORE

Front / Avant / Vorderrad / Delantera

N° 2 Cushion 22x8x16

POSTERIORE

Rear / Arrière / Hinterrad / Trasera

N° 2 Cushion
406x152x267

IMPIANTO IDRAULICO

Hydraulics (Max pressure/Motor power)
Hydraulique (Pression maxi/Puissance moteur)
Hydraulik (Max Druck/Motorleistung)
Hidraulica (Presion max/Potencia motor)

220 Bar – 8 kW AC

TRAZIONE ANTERIORE

Rear-wheel drive / À traction arrière
Heckantrieb / Tracción trasera

2 x 1,9 kW AC

STERZATURA POSTERIORE

Rear steering / Direction arrière
Hintere Lenkung / Dirección trasera

600 W AC – 180°

BATTERIA

Battery / Batterie / Batterie / Batterie

80V – 400 Ah

CONTRAPPESO

Counterweights / Contrepoids
Gegengewichte / Contrapesos

1.830 kg

FRENI ELETTRICI

Electro Brakes / Freins electro / ElektroBremse / Frenos electros



V60R

EQUIPAGGIAMENTI

Equipments / Équipement
Ausrüstung / Equipamiento



STANDARD

RUOTE ANTI-TRACCIA

Non-marking tires / Roues non marquant
Non-Marking-Räder / Ruedas anti-marcas

TESTA AD INCLINAZIONE VARIABILE

Variable tilt head / Tête à inclinaison variable
Variabler Neigungskopf / Cabezal ajustable

RADIOCOMANDO

Radio-control / Radiocommande
Radio Kontrolle / Radio control

GANCIO

Hook / Crochet / Haken / Gancho



OPTIONAL

ARGANO

Winch / Treuil / Winde / Cabrestante

JIB MECCANICO RIPIEGABILE

Foldable mechanic jib / Flechette mécanique pliable
Klappbarer mechanischer Ausleger / Pluma mecanica plegable

JIB IDRAULICO RIPIEGABILE

Foldable hydraulic jib / Flechette hydraulique pliable
Klappbarer hydraulischer Ausleger / Pluma hidráulica plegable

FORCHE AUTOLIVELLANTI

Self-levelling forks / Fourches autonivelantes
Selbstnivellierende Gabeln / Horquillas autonivelantes

BATTERIE AL LITIO

Lithium batteries / Batteries à lithium
Lithiumbatterien / Baterías de litio

TRASFORMAZIONE ATEX

ATEX transformation / Transformation ATEX
ATEX-Umwandlung / Transformación ATEX

VALLA CONNECT SYSTEM



V 60 R

INGOMBRI PRINCIPALI - VERSIONE CON GANCIO

Main dimension - Hook version

Dimensions principales - Version avec crochet

Hauptabmessungen - Version mit Haken

Dimensiones principales - Versión con gancho

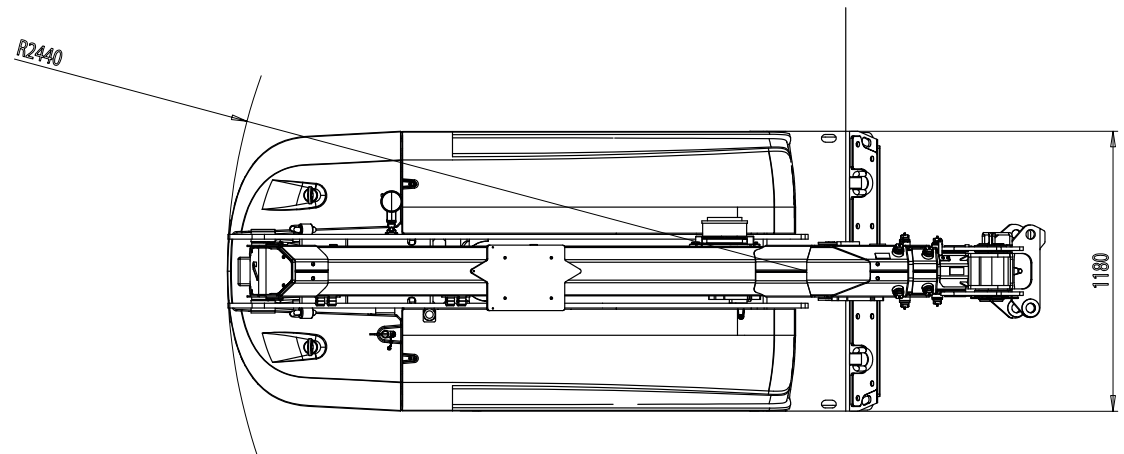
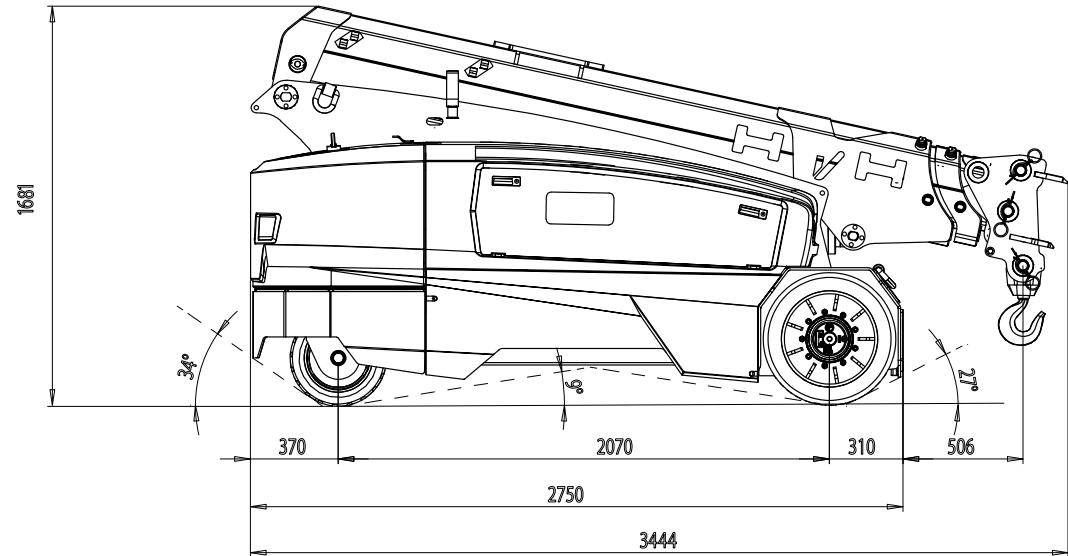
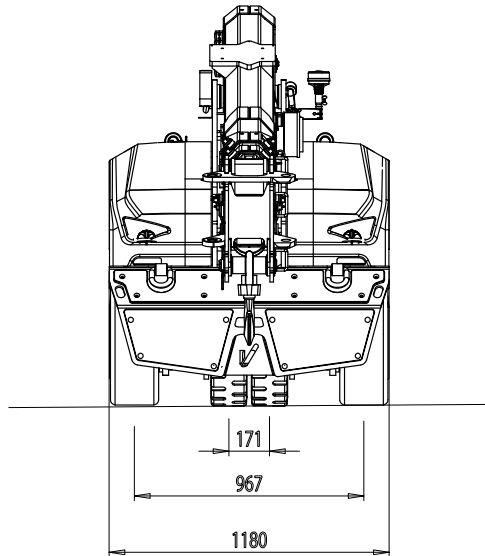

V 6 0 R

INGOMBRI PRINCIPALI - VERSIONE CON GANCIO

Main dimension - Hook version

Dimensions principales - Version avec crochet

Hauptabmessungen - Version mit Haken

Dimensiones principales - Versión con gancho

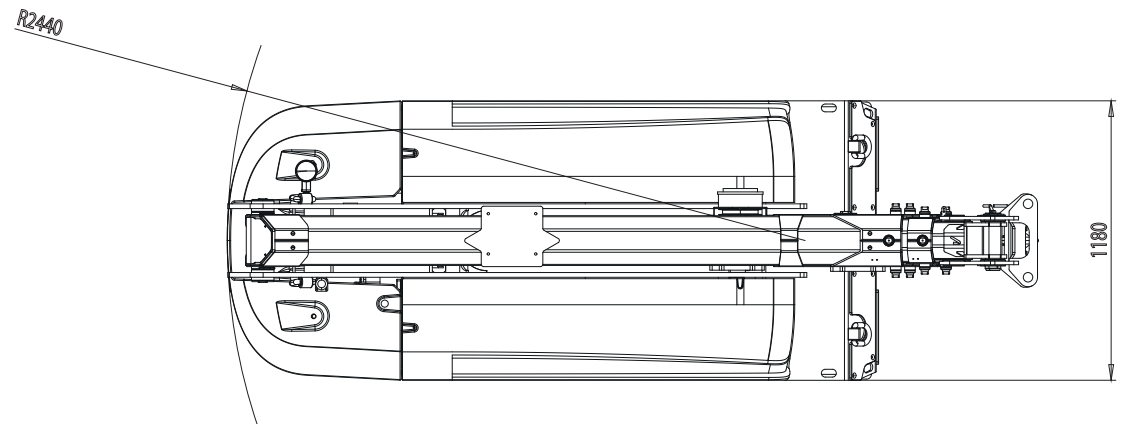
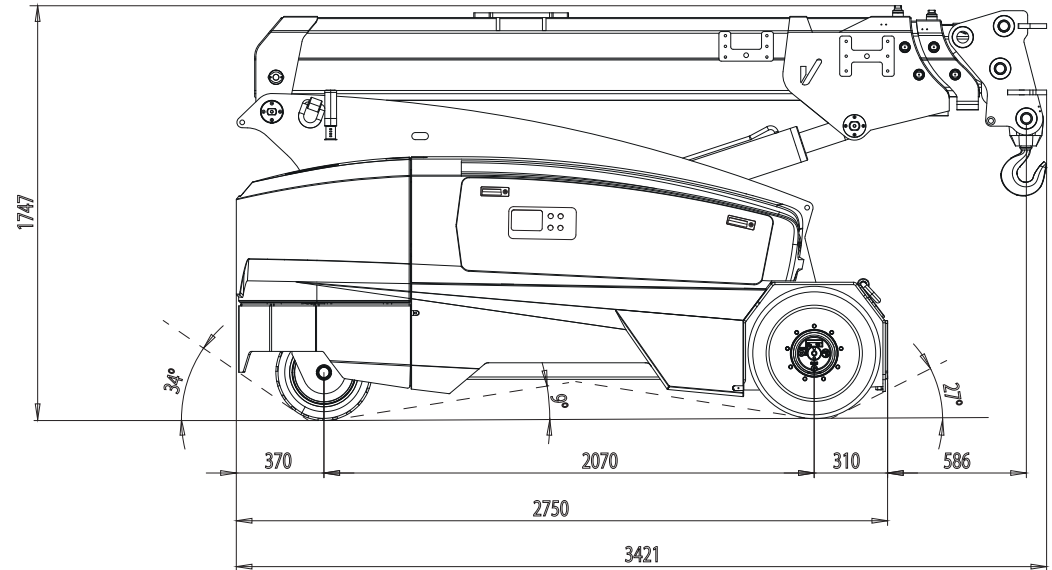
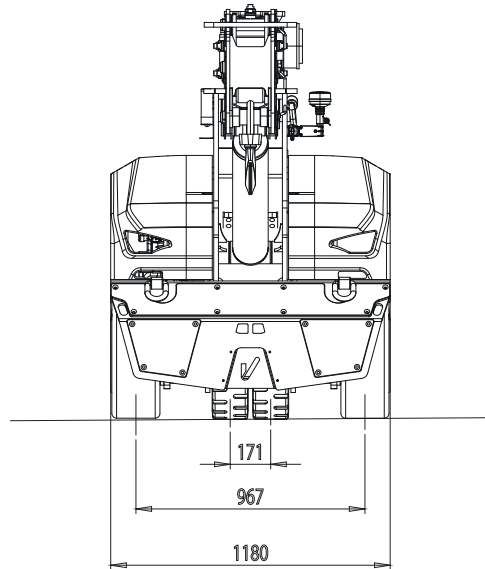

V 6 0 R

INGOMBRI PRINCIPALI - VERSIONE CON ARGANO

Main dimension - Winch version

Dimensions principales - Version avec treuil

Hauptabmessungen - Ausführung mit Winde

Dimensiones principales - Cabrestante versión

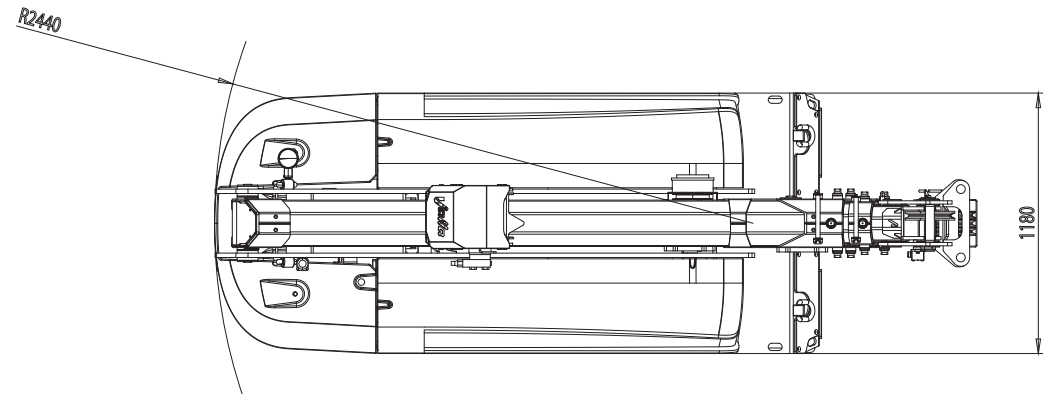
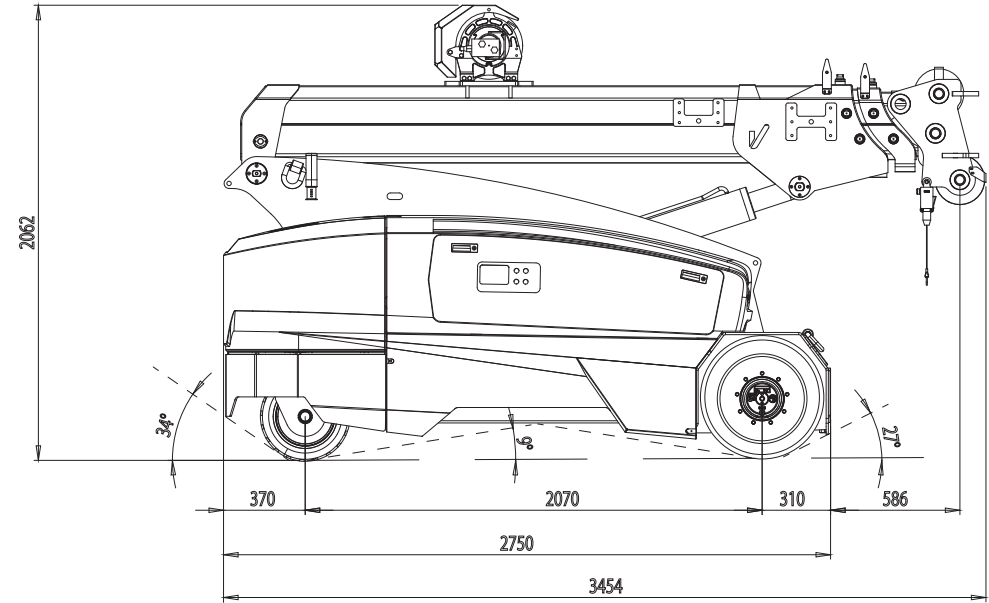
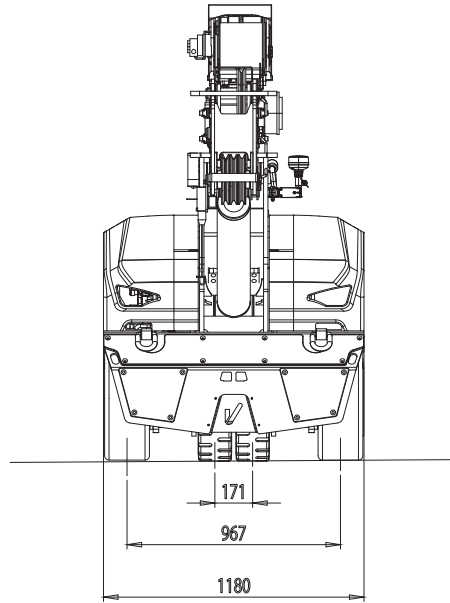

V 60 R

INGOMBRI PRINCIPALI - VERSIONE CON JIB IDRAULICO RIPIEGABILE

Main dimension - Foldable hydraulic jib version

Dimensions principales - Version avec flechette hydraulique pliable

Hauptabmessungen - Version mit Klappbarer hydraulischer Ausleger

Dimensiones principales - Versión con pluma hidráulica plegable

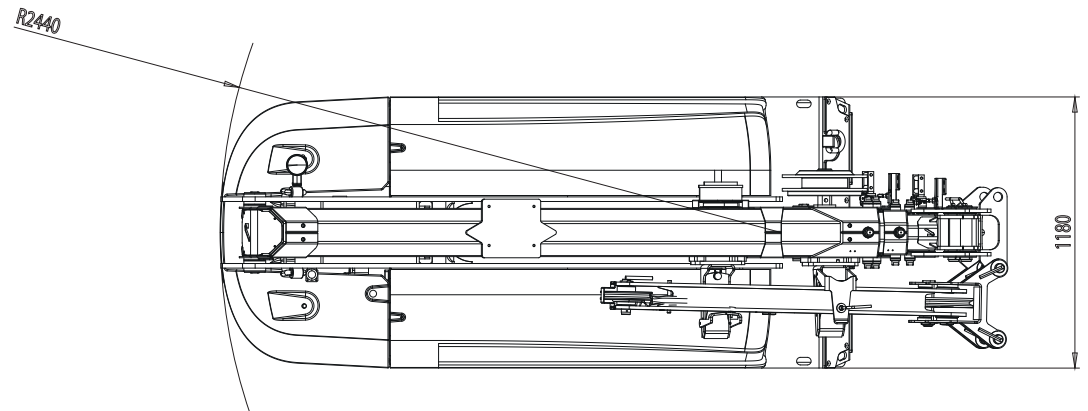
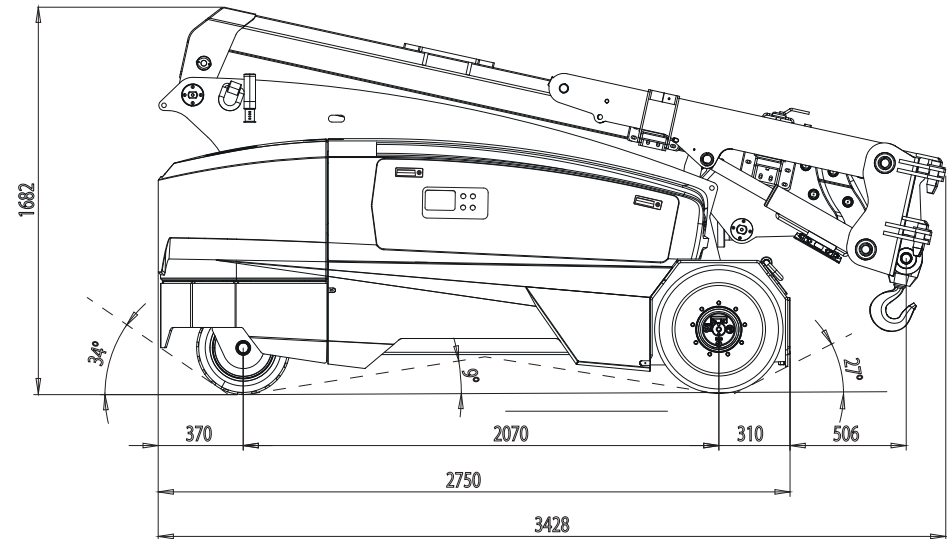
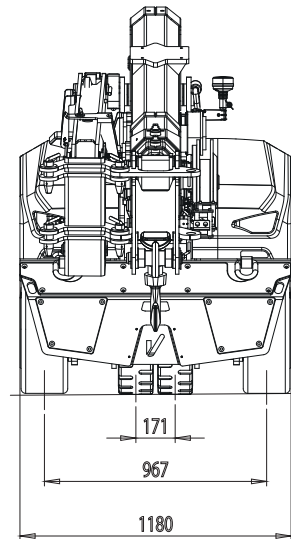

V 60 R

INGOMBRI PRINCIPALI - VERSIONE CON JIB IDRAULICO RIPIEGABILE

Main dimension - Foldable hydraulic jib version

Dimensions principales - Version avec flechette hydraulique pliable

Hauptabmessungen - Version mit Klappbarer hydraulischer Ausleger

Dimensiones principales - Versión con pluma hidráulica plegable

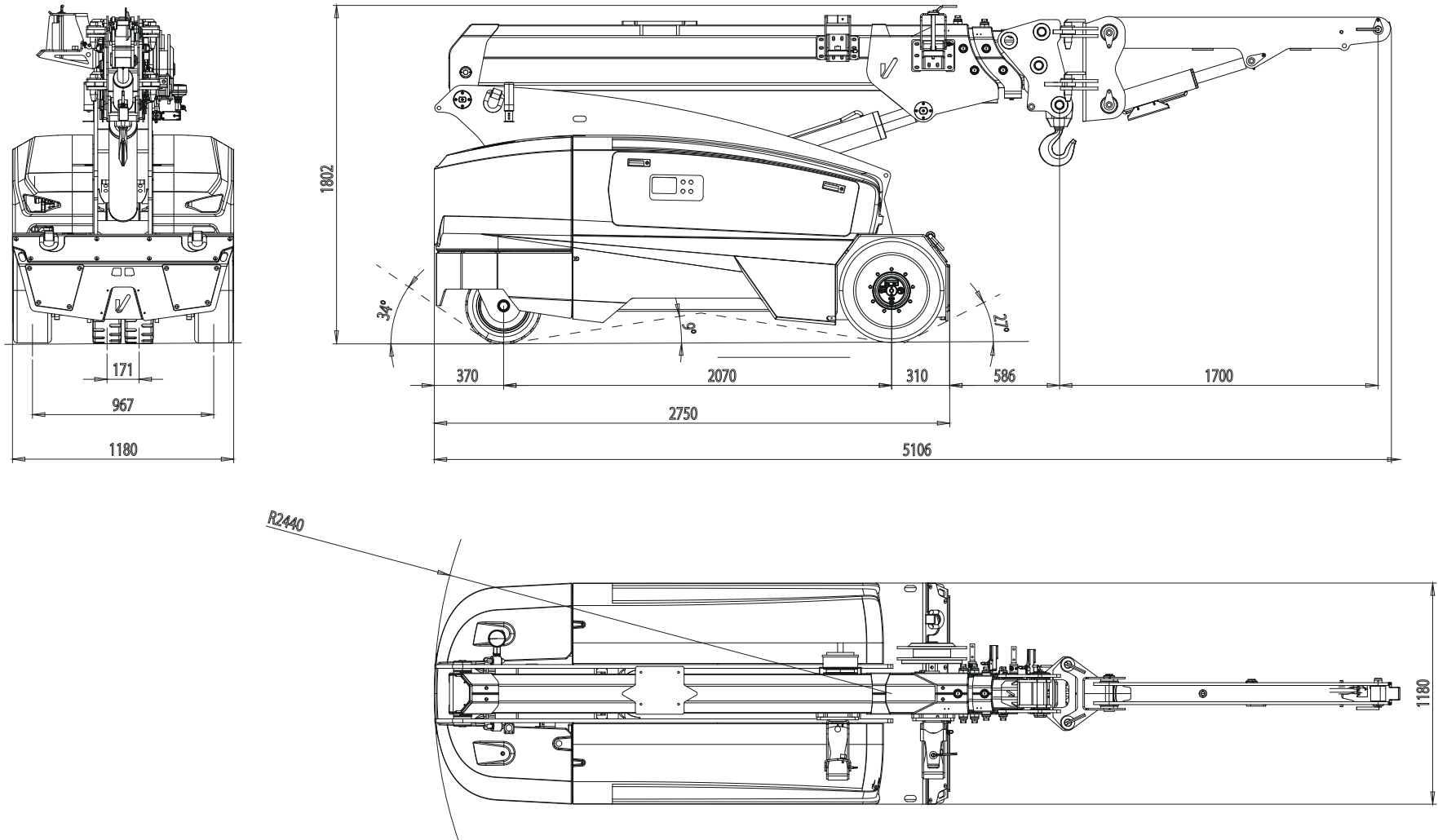

V 6 0 R

INGOMBRI PRINCIPALI - VERSIONE CON ARGANO E JIB IDRAULICO RIPIEGABILE

Main dimension - Winch and foldable hydraulic jib version

Dimensions principales - Version avec treuil et flechette hydraulique pliable

Hauptabmessungen - Version mit Winde und Klappbarer hydraulischer Ausleger

Dimensiones principales - Versión con cabrestante y pluma hidráulica plegable

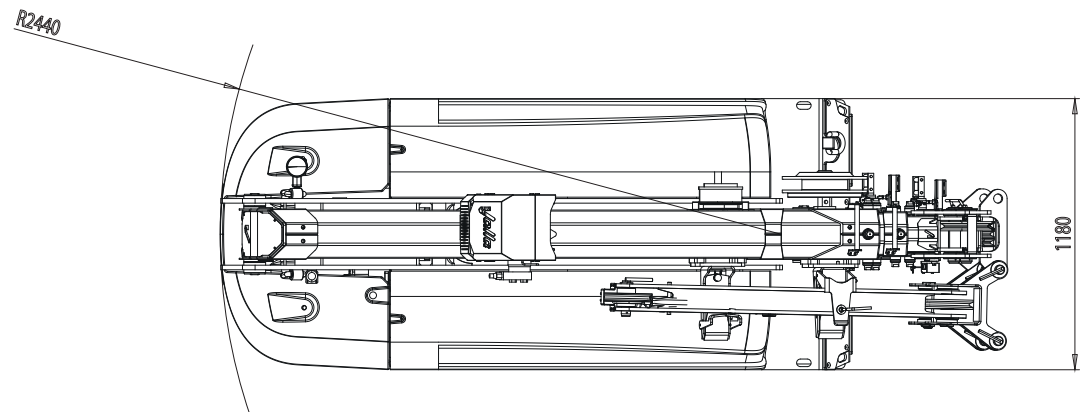
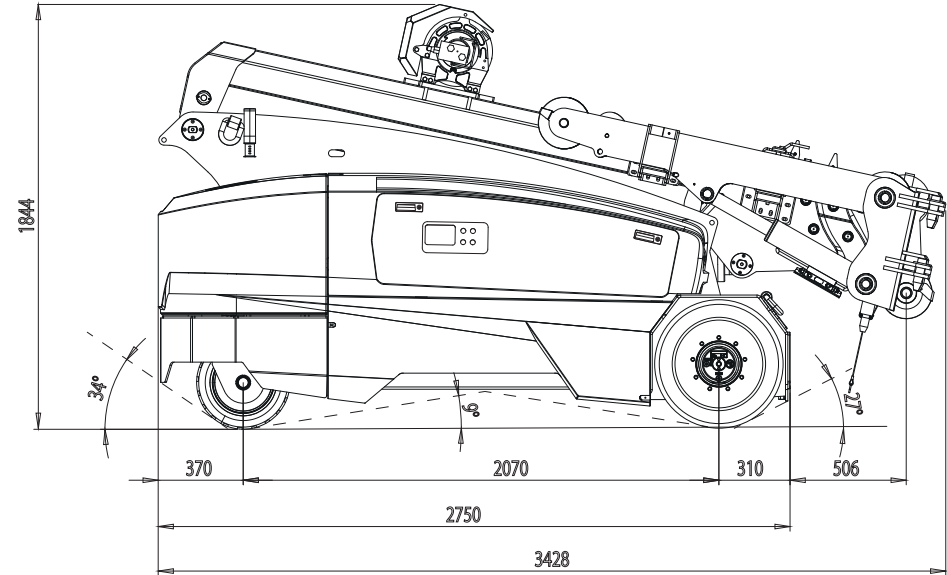
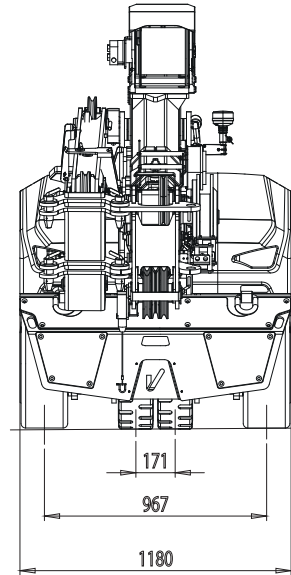

V 6 0 R

INGOMBRI PRINCIPALI - VERSIONE CON ARGANO E JIB IDRAULICO RIPIEGABILE

Main dimension - Winch and foldable hydraulic jib version

Dimensions principales - Version avec treuil et flechette hydraulique pliable

Hauptabmessungen - Version mit Winde und Klappbarer hydraulischer Ausleger

Dimensiones principales - Versión con cabrestante y pluma hidráulica plegable

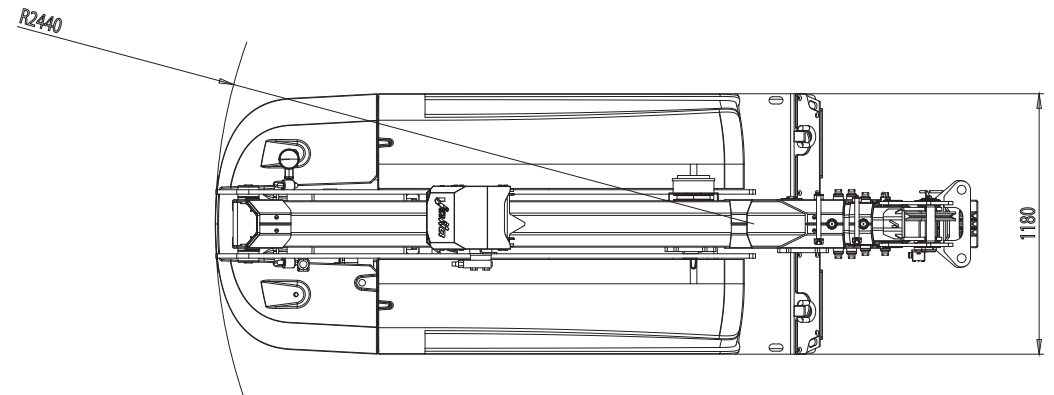
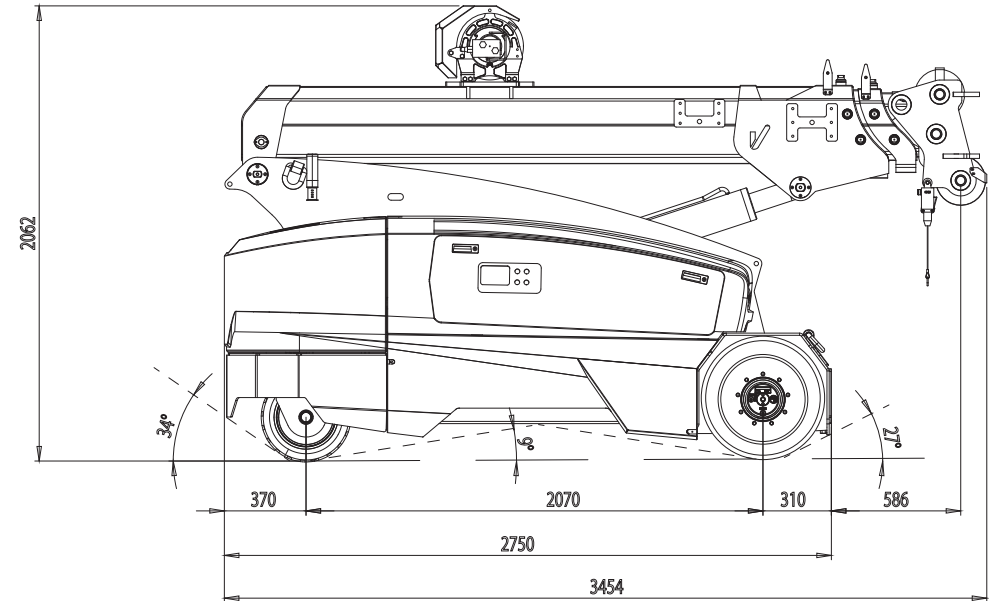
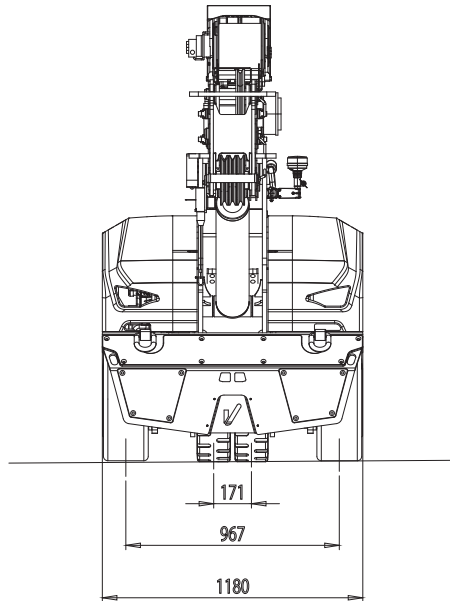

V 6 0 R

INGOMBRI PRINCIPALI - VERSIONE CON ARGANO E JIB IDRAULICO RIPIEGABILE

Main dimension - Winch and foldable hydraulic jib version

Dimensions principales - Version avec treuil et flechette hydraulique pliable

Hauptabmessungen - Version mit Winde und Klappbarer hydraulischer Ausleger

Dimensiones principales - Versión con cabrestante y pluma hidráulica plegable

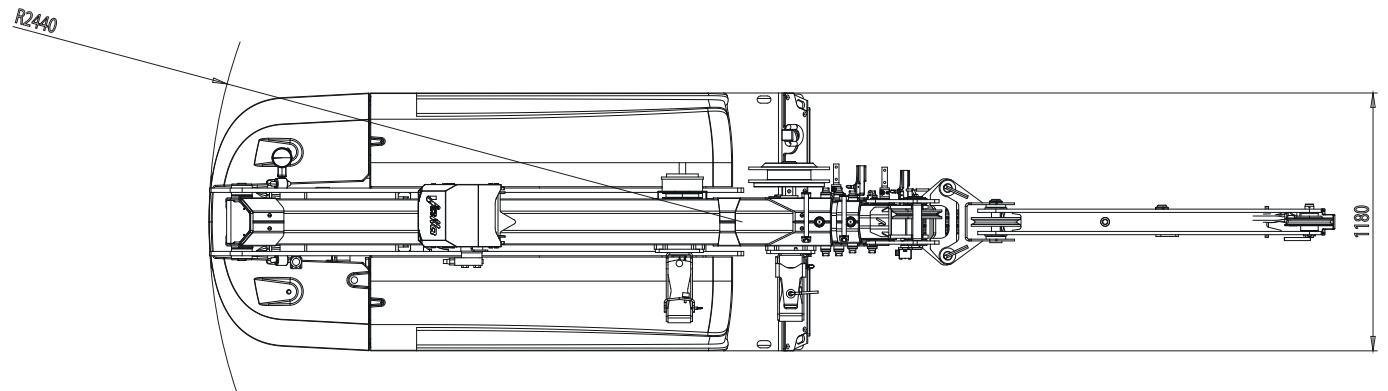
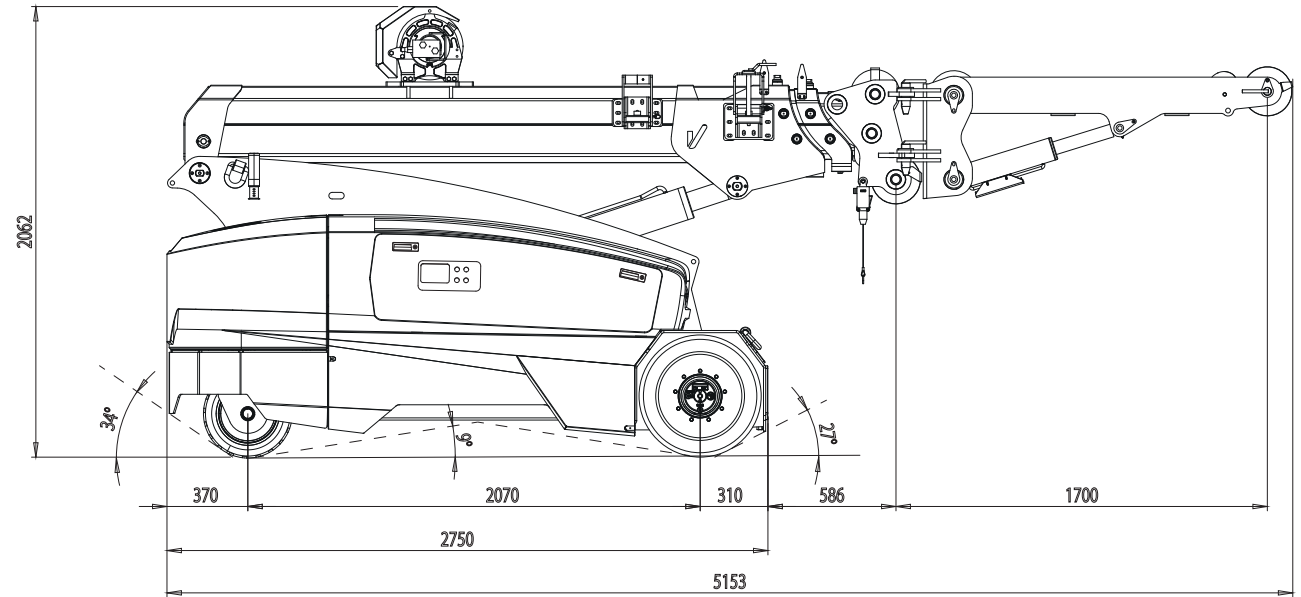
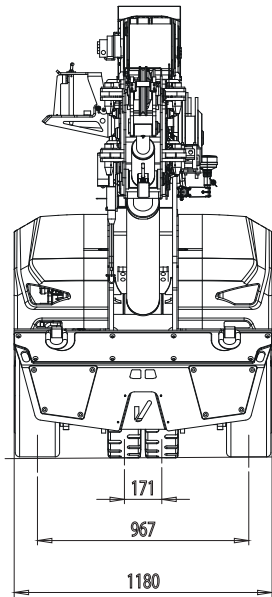

V 6 0 R

DIAGRAMMA DI PORTATA (t) - VERSIONE CON GANCIO

Load diagram (t) - Hook version

Tableau des charges utiles (t) - Version avec crochet

Traglastdiagramm (t) - Version mit Haken

Diagrama de las capacidades de carga (t) - Versión con gancho

cod. 188.372 Rev A

POS. 1

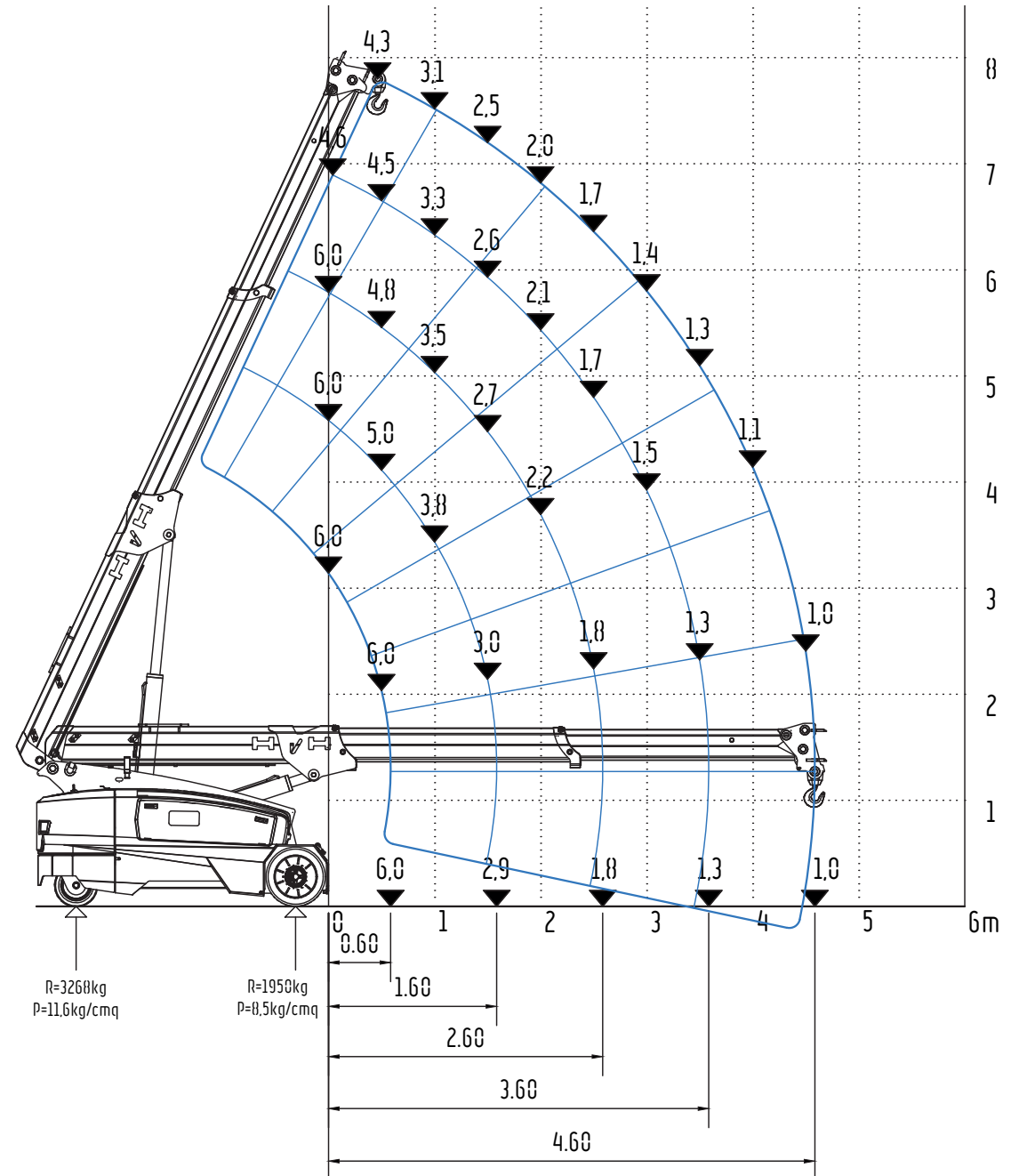

V 6 0 R

DIAGRAMMA DI PORTATA (t) - VERSIONE CON GANCIO

Load diagram (t) - Hook version

Tableau des charges utiles (t) - Version avec crochet

Traglastdiagramm (t) - Version mit Haken

Diagrama de las capacidades de carga (t) - Versión con gancho

cod. 188.372 Rev A

POS. 2

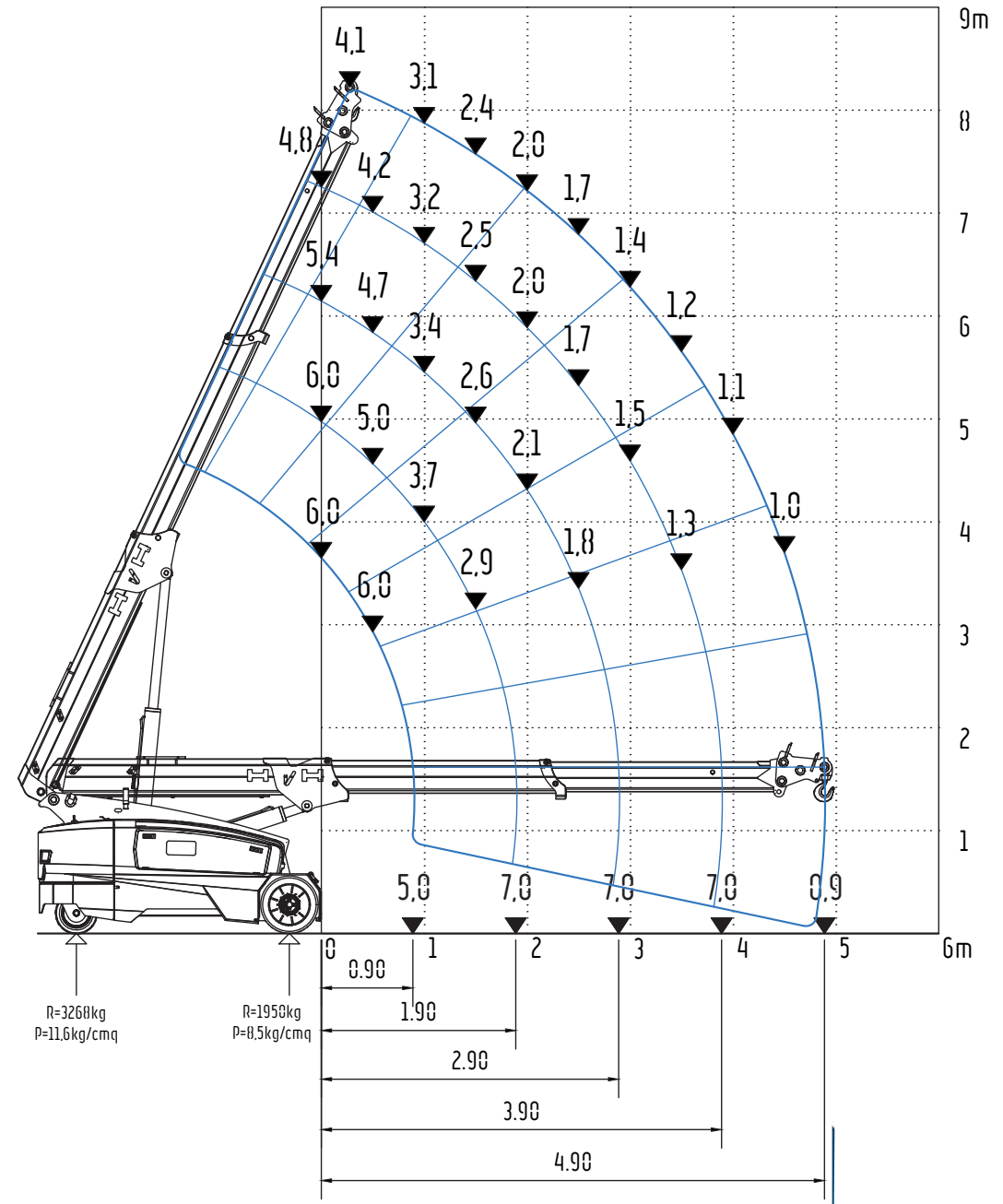

V 6 0 R

DIAGRAMMA DI PORTATA (t) VERSIONE CON ARGANO A ZERO ZAVORRE

Load diagram (t) - Winch version without counterweights
 Tableau des charges utiles (t) - Version avec treuil sans contrepoids
 Traglastdiagramm (t) - Version mit Winde ohne Gegengewichte
 Diagrama de las capacidades de carga (t) - Cabrestante versión sin contrapesos

cod. 188.277 Rev A

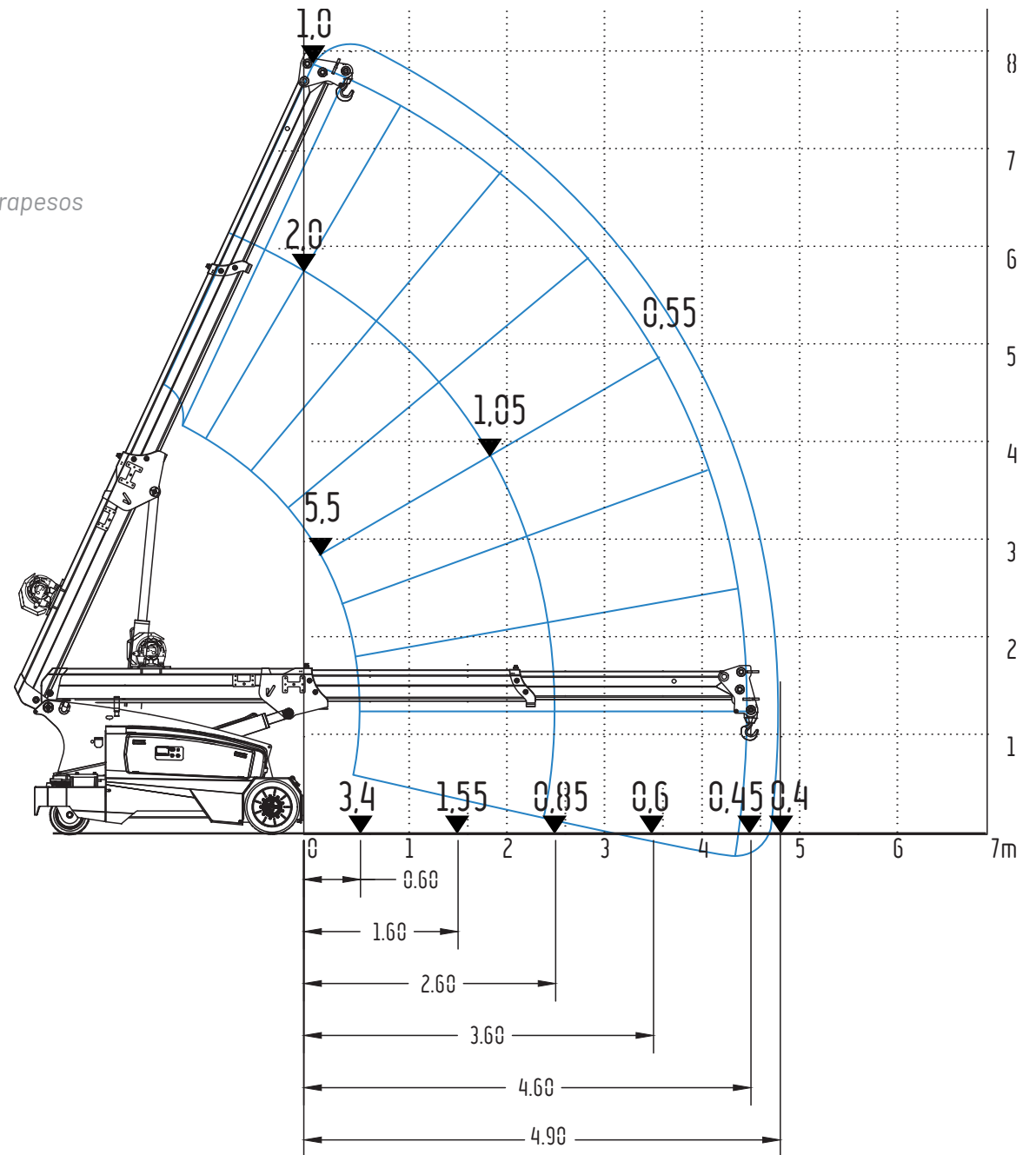

V 6 0 R

DIAGRAMMA DI PORTATA (t) VERSIONE CON ARGANO E JIB IDRAULICO RIPIEGABILE

Load diagram (t) - Winch and foldable hydraulic jib version
 Tableau des charges utiles (t) - Version avec treuil et flechette hydraulique pliable
 Traglastdiagramm (t) - Version mit Winde und Klappbarer hydraulischer Ausleger
 Diagrama de las capacidades de carga (t) - Versión con cabrestante y pluma hidráulica plegable

cod. 188.276 Rev A

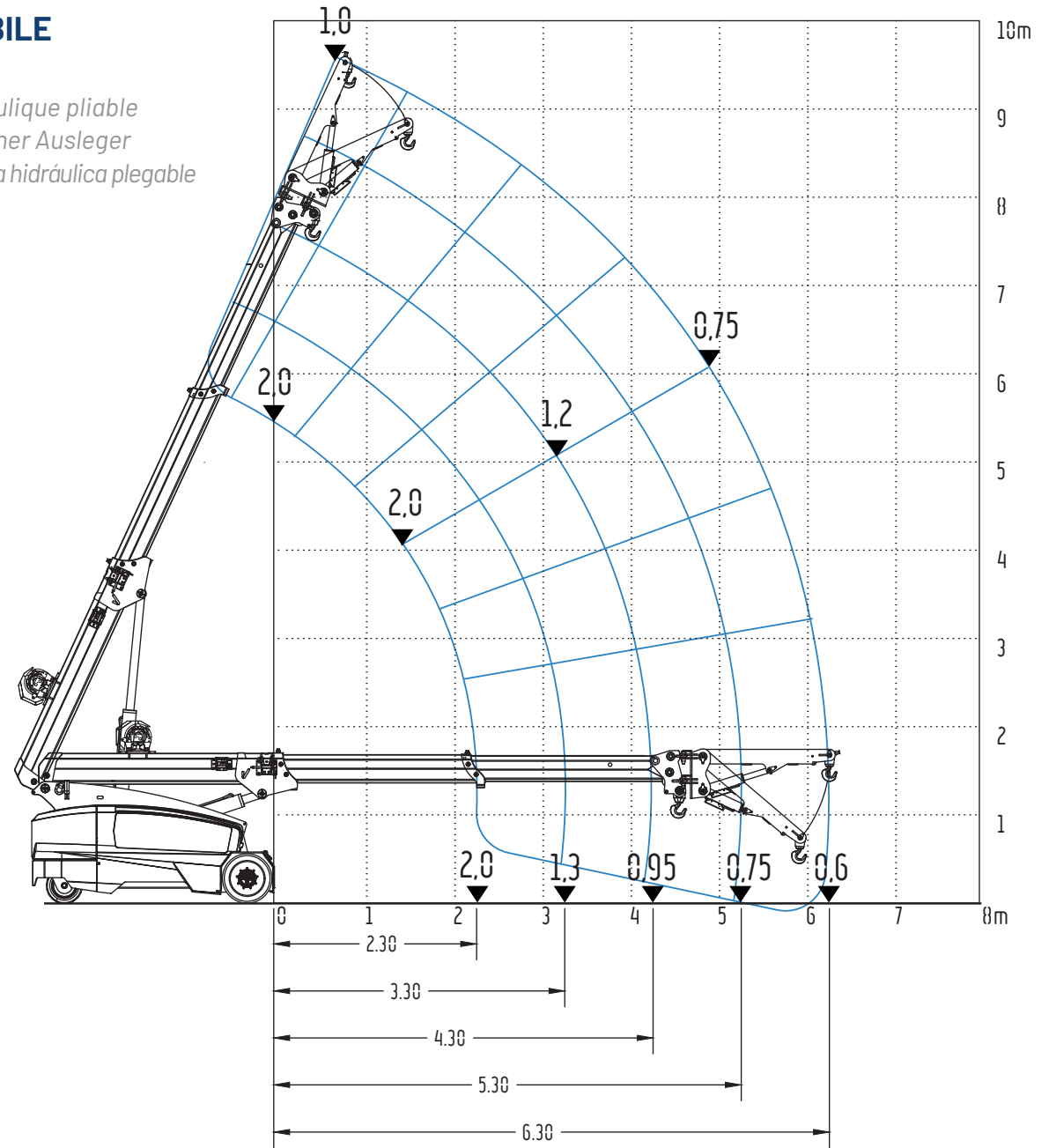



+44 (0)1482 481960

info@valla-cranes.co.uk

Northern

(Head Office)
English Street,
Hull HU3 2BS

Central

Shaw Lane Industrial Estate
Ogden Road, Doncaster
DN2 4SQ

Southern

Unit 8, Redhill 23 Business Park
Holmethorpe Avenue,
Redhill RH1 2NB

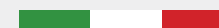

Valla is a brand of Manitex International

Dati tecnici e caratteristiche possono subire variazioni senza preavviso. Le macchine rappresentate potrebbero avere accessori opzionali. Le misure indicate nel documento possono avere una tolleranza del valore di +/-3%.

Technical data and features are subject to change without notice, machines shown may have optional accessories. The measurements indicated in the document may have a tolerance of +/-3%.

Les données techniques et les caractéristiques peuvent être modifiées sans préavis, les machines illustrées peuvent avoir des accessoires en option. Les mesures indiquées dans le document peuvent avoir une tolérance de +/-3%.

Eigenschaften und technische Daten können ohne Vorankündigung geändert werden.

Die angezeigten Maschinen könnten Sonderausstattungen haben. Die im Dokument angegebenen Maße können eine Toleranz von +/-3 % haben.

Los datos técnicos y las características están sujetos a cambios sin previo aviso, las máquinas que se muestran pueden tener accesorios opcionales. Las medidas indicadas en el documento pueden tener una tolerancia de +/-3%.