

Valla
MANITEX



HIRD
SALES

V 7 0 R
RADIOCOMANDATA

SCHEDA PRODOTTO
Product details / Détails du produit
Produktdetails/ Detalles de producto

V70R

INFORMAZIONI TECNICHE

Technical information / Informations techniques
Technische information / Información técnica



PORTATA MASSIMA

Max payload / Capacité maxi **7.000 kg**
Max Tragfähigkeit / Max capacidad

PESO TOTALE

Total weight / Poids total **7.500 kg**
Gesamtgewicht / Peso total

SBRACCIO MASSIMO

Max boom extension / Déport maximum **9,4 m**
Maximale Auslegerverlängerung / Alcance máximo

DIMENSIONI

Dimensions / Dimensions **3.190 x 1.400 x 1.895 mm**
Abmessungen / Dimensiones

ANTERIORE

Front / Avant / Vorderrad / Delantera **N° 2 S.E. 250-15**

POSTERIORE

Rear / Arrière / Hinterrad / Trasera **N° 2 S.E. 23x9x10**

IMPIANTO IDRAULICO

Hydraulics (Max pressure/Motor power) **220 Bar 12 kW**
Hydraulique (Pression maxi/Puissance moteur)
Hydraulik (Max Druck/Motorleistung)
Hidraulica (Presion max/Potencia motor)

TRAZIONE ANTERIORE

Rear-wheel drive / À traction arrière **2 x 4.2 kW**
Heckantrieb / Tracción trasera

STERZATURA POSTERIORE

Rear steering / Direction arrière **800W AC - 180°**
Hintere Lenkung / Dirección trasera

BATTERIA

Battery / Batterie / Batterie / Batterie **80V - 560 Ah**

FRENI ELETTRIDRAULICI ANTERIORI

Front electro-hydraulic brakes / Freins électro-hydrauliques avant
Elektrohydraulische Vorderradbremßen / frenos electrohidráulicos delanteros

CONTRAPPESI REMOVIBILI

Removable counterweights / Contrepoids amovibles **N° 2 x 900 kg**
Abnehmbare Gegengewichte / Contrapesos removibles



V70R

EQUIPAGGIAMENTI

Equipments / Équipement
Ausrüstung / Equipamiento



STANDARD

RUOTE ANTI-TRACCIA

Non-marking tires / Roues non marquant
Non-Marking-Räder / Ruedas anti-marcas

TESTA AD INCLINAZIONE VARIABILE

Variable tilt head / Tête à inclinaison variable
Variabler Neigungskopf / Cabezal ajustable

RADIOCOMANDO

Radio-control / Radiocommande
Radio Kontrolle / Radio control

GANCIO

Hook / Crochet / Haken / Gancho



OPTIONAL

ARGANO

Winch / Treuil / Winde / Cabrestante

JIB MECCANICO RIPIEGABILE

Foldable mechanic jib / Flechette mécanique pliable
Klappbarer mechanischer Ausleger / Pluma mecánica plegable

JIB IDRAULICO RIPIEGABILE

Foldable hydraulic jib / Flechette hydraulique pliable
Klappbarer hydraulischer Ausleger / Pluma hidráulica plegable

FORCHE AUTOLIVELLANTI

Self-levelling forks / Fourches autonivelantes
Selbstnivellierende Gabeln / Horquillas autonivelantes

BATTERIE AL LITIO

Lithium batteries / Batteries à lithium
Lithiumbatterien / Baterías de litio

TRASFORMAZIONE ATEX

ATEX transformation / Transformation ATEX
ATEX-Umwandlung / Transformación ATEX

VALLA CONNECT SYSTEM



V70R

INGOMBRI PRINCIPALI - VERSIONE CON GANCIO

Main dimension - Hook version

Dimensions principales - Version avec crochet

Hauptabmessungen - Version mit Haken

Dimensiones principales - Versión con gancho

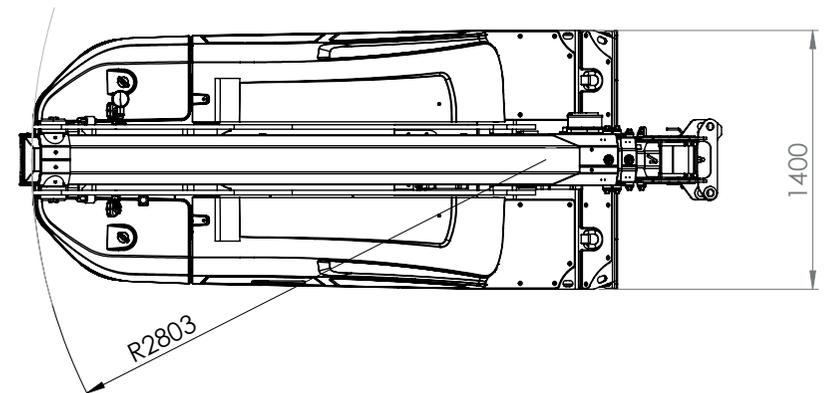
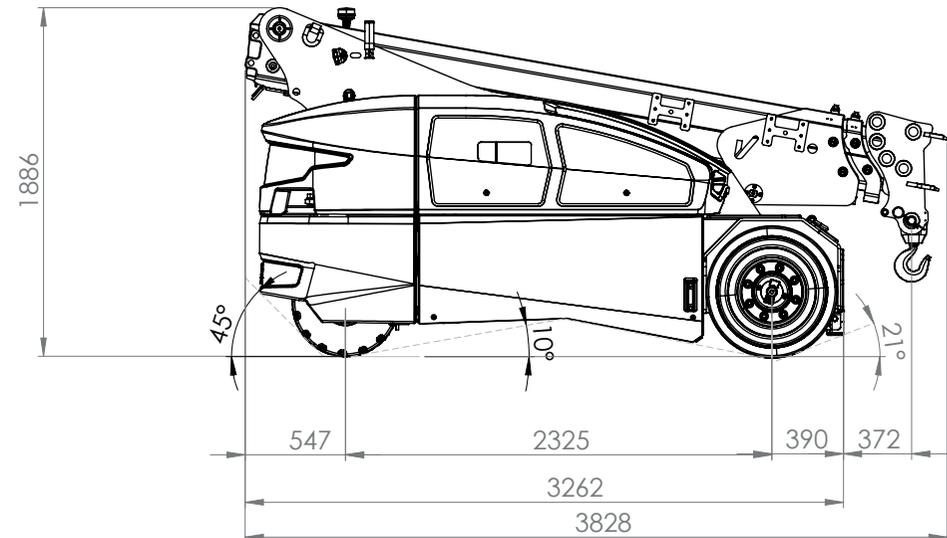
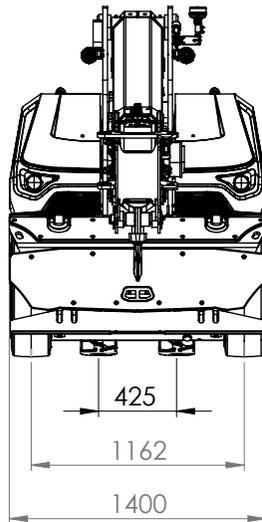

V70R

INGOMBRI PRINCIPALI - VERSIONE CON ARGANO

Main dimension - Winch version

Dimensions principales - Version avec treuil

Hauptabmessungen - Version mit Winde

Dimensiones principales - Versión con cabrestante

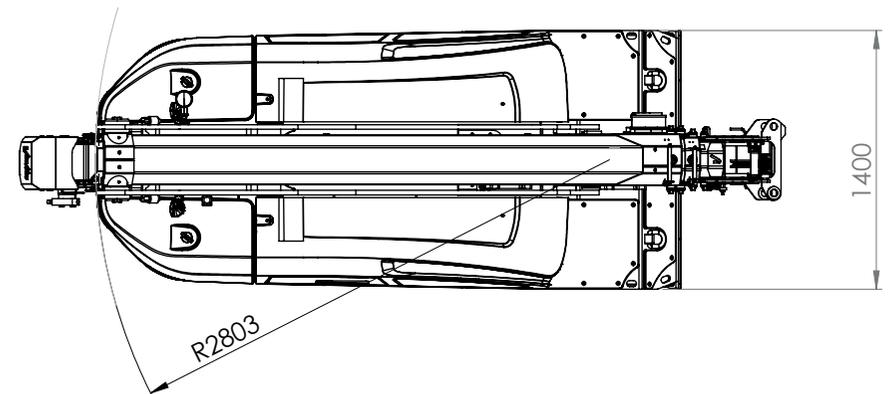
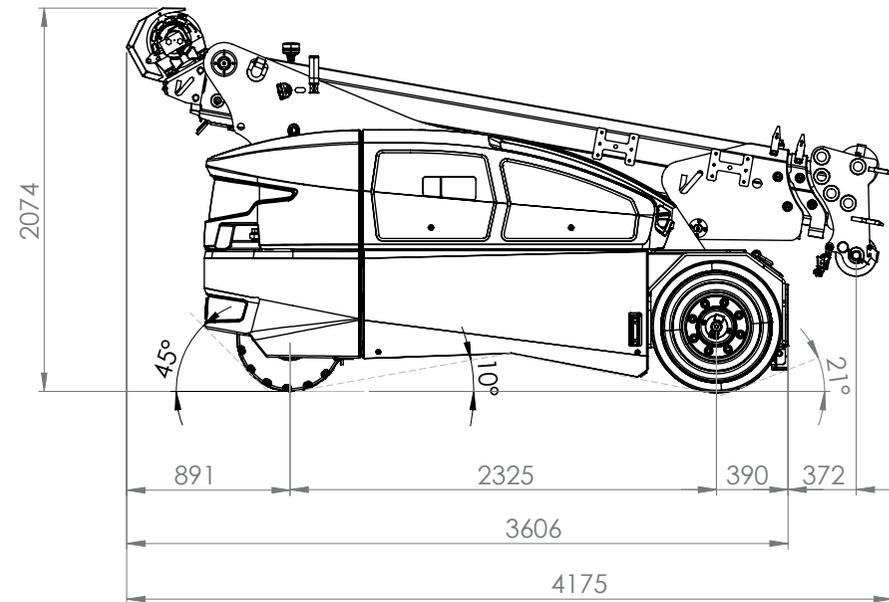
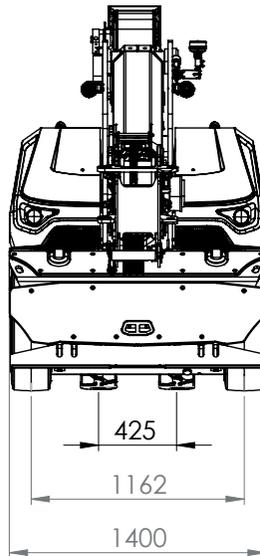

V70R

INGOMBRI PRINCIPALI - VERSIONE CON JIB IDRAULICO RIPIEGABILE

Main dimension - Foldable hydraulic jib version

Dimensions principales - Version avec flechette hydraulique pliable

Hauptabmessungen - Version mit Klappbarer hydraulischer Ausleger

Dimensiones principales - Versión con pluma hidráulica plegable

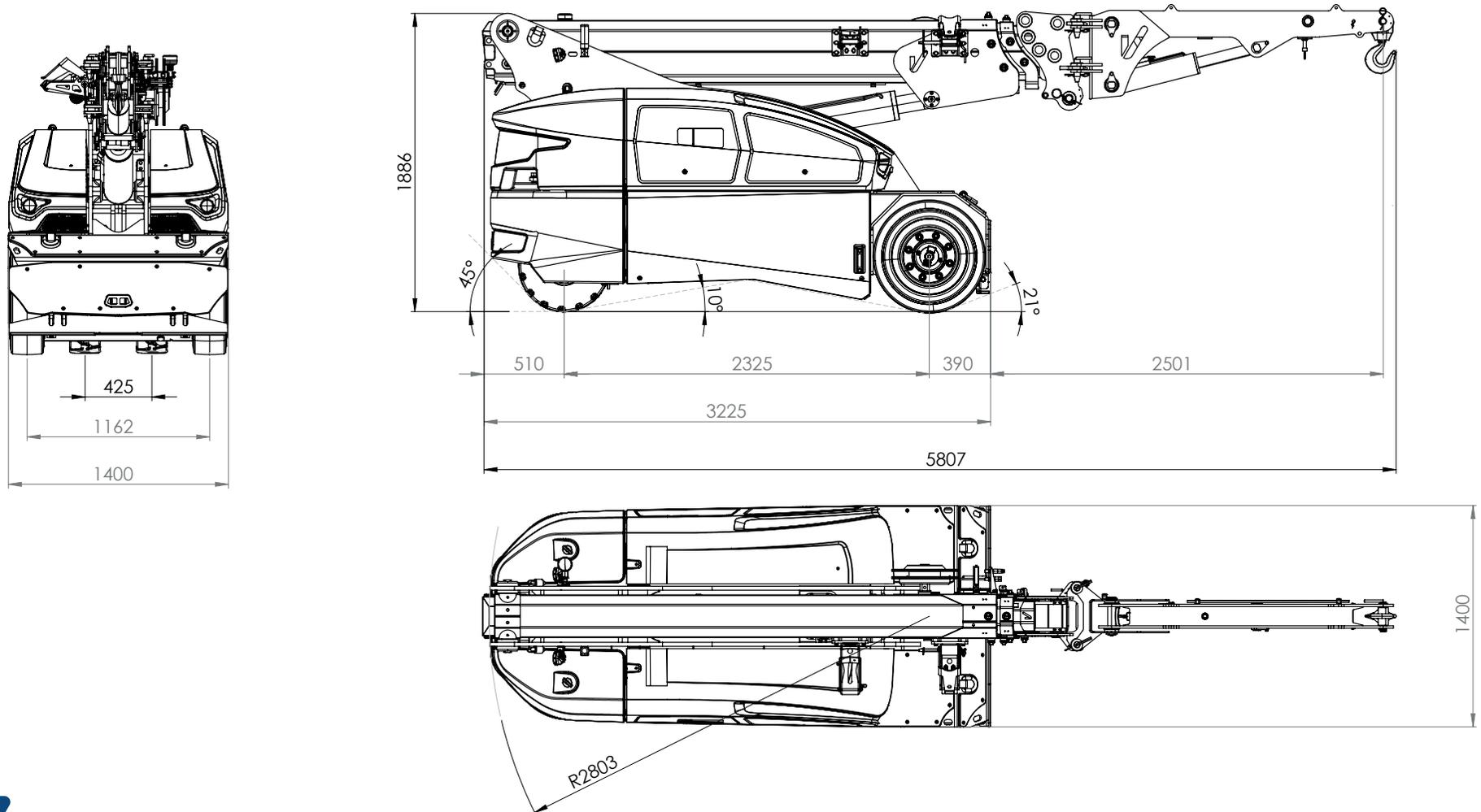

V70R

INGOMBRI PRINCIPALI - VERSIONE CON ARGANO E JIB IDRAULICO RIPIEGABILE

Main dimension - Winch and foldable hydraulic jib version

Dimensions principales - Version avec treuil et flechette hydraulique pliable

Hauptabmessungen - Version mit Winde und Klappbarer hydraulischer Ausleger

Dimensiones principales - Versión con cobrestante y pluma hidráulica plegable

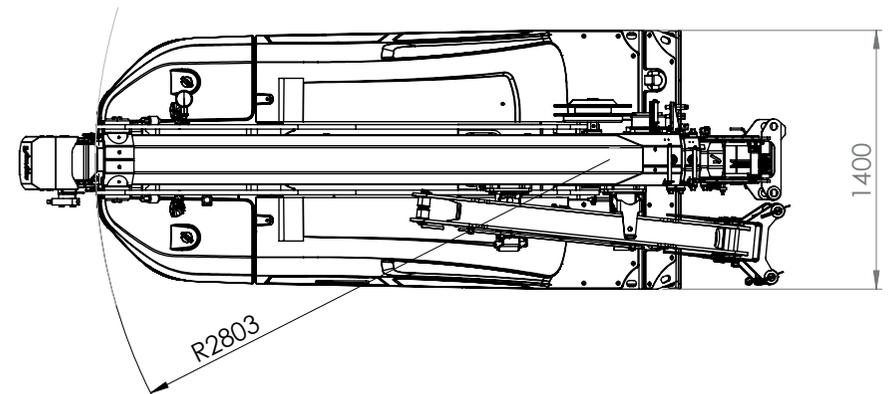
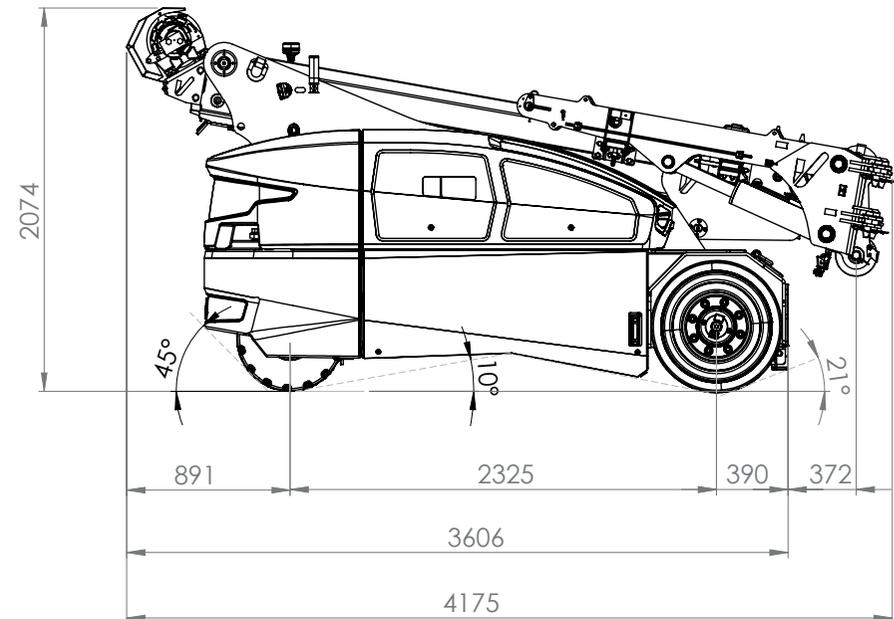
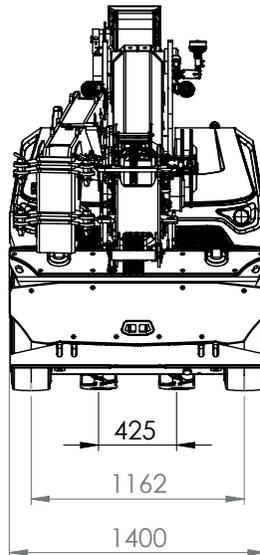

V70R

INGOMBRI PRINCIPALI - VERSIONE CON ARGANO E JIB IDRAULICO RIPIEGABILE

Main dimension - Winch and foldable hydraulic jib version

Dimensions principales - Version avec treuil et flechette hydraulique pliable

Hauptabmessungen - Version mit Winde und Klappbarer hydraulischer Ausleger

Dimensiones principales - Versión con cobrestante y pluma hidráulica plegable

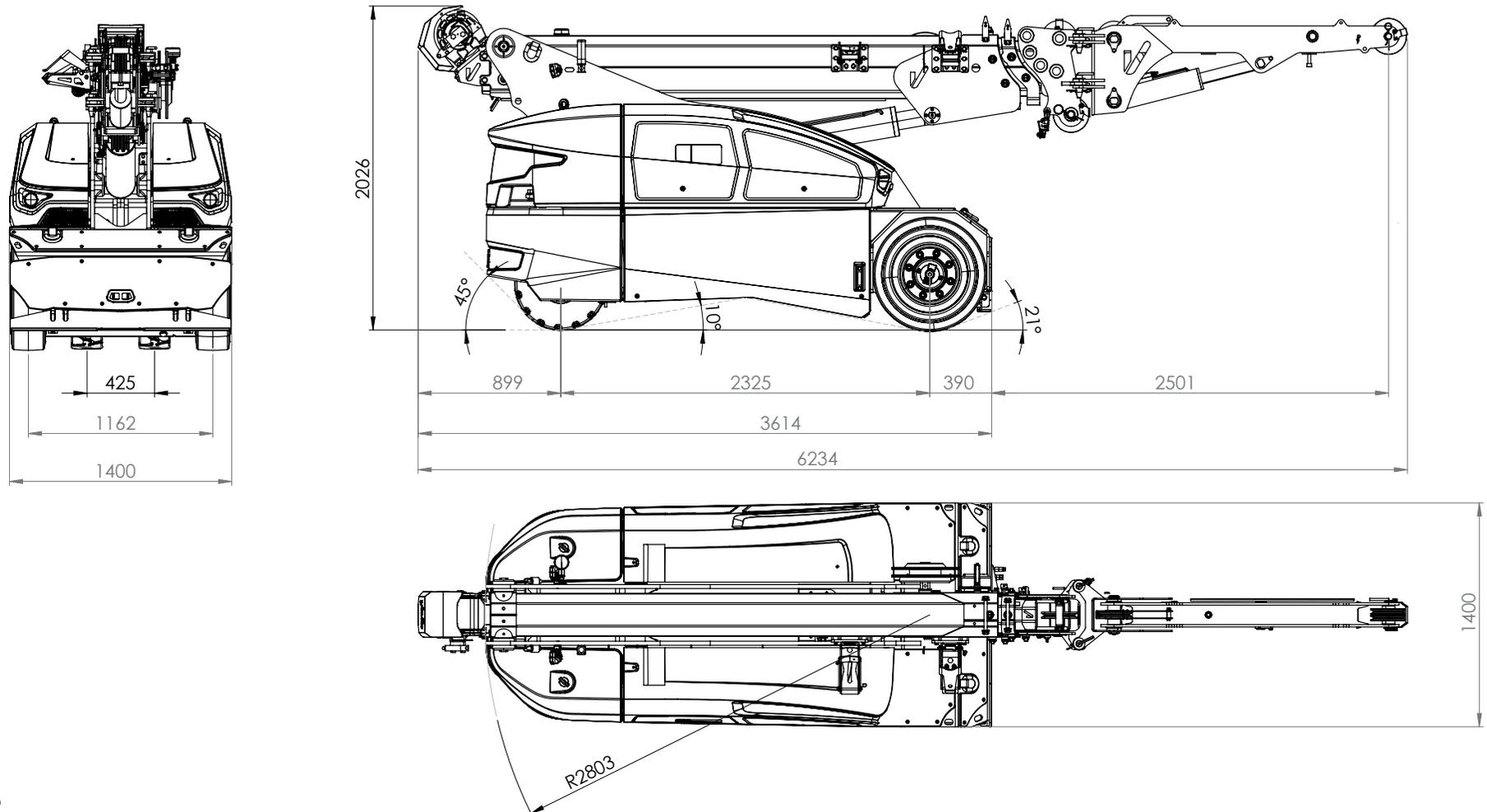

V70R

INGOMBRI PRINCIPALI - VERSIONE CON FORCHE

Main dimension - Forks version

Dimensions principales - Version avec fourches

Hauptabmessungen - Version mit Gabeln

Dimensiones principales - Versión con horquillas

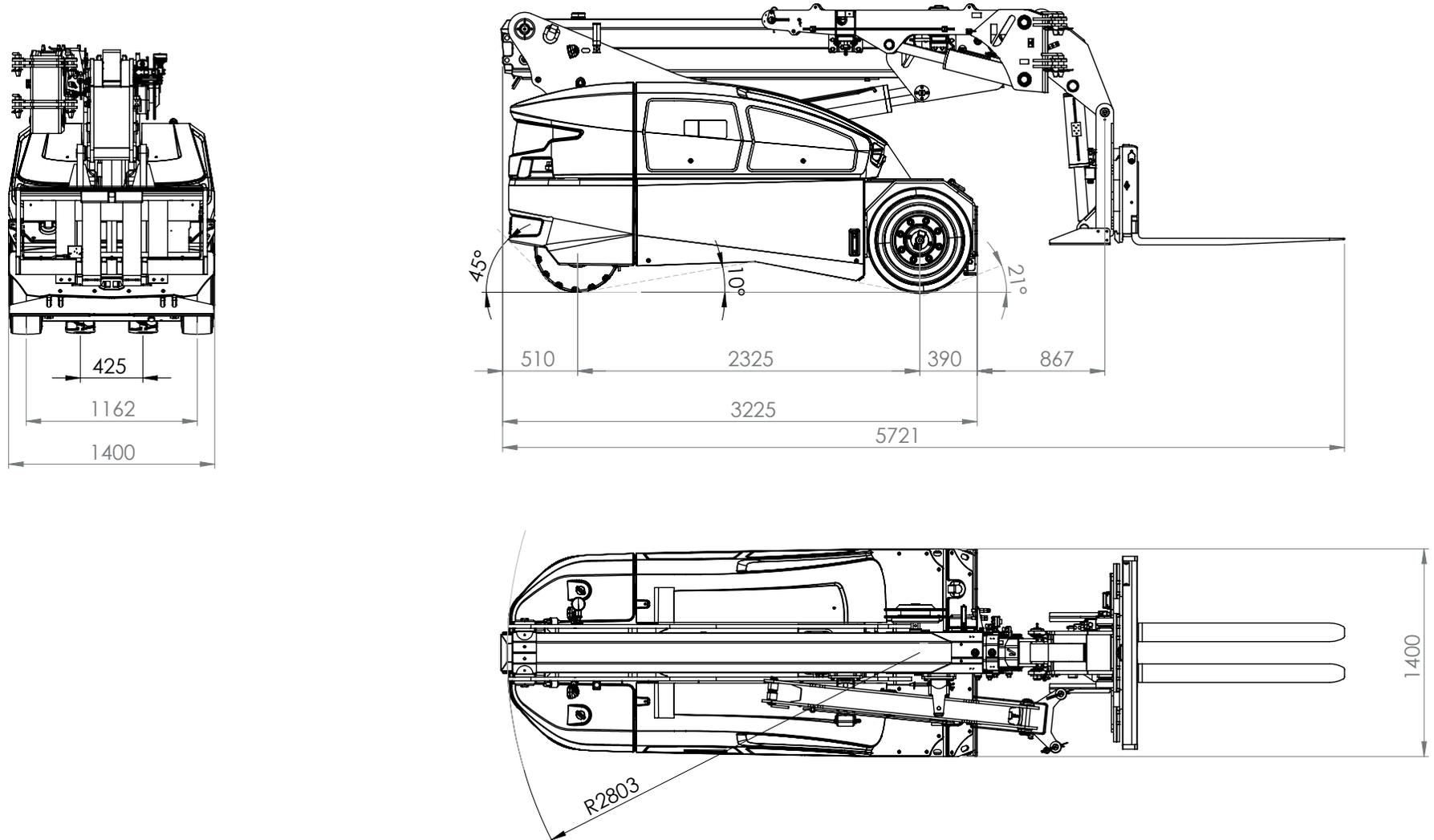

V70R

DIAGRAMMA DI PORTATA (t) - VERSIONE CON GANCIO

Load diagram (t) - Hook version

Tableau des charges utiles (t) - Version avec crochet

Traglastdiagramm (t) - Version mit Haken

Diagrama de las capacidades de carga (t) - Versión con gancho

cod. 188.361 Rev A

POS. 1

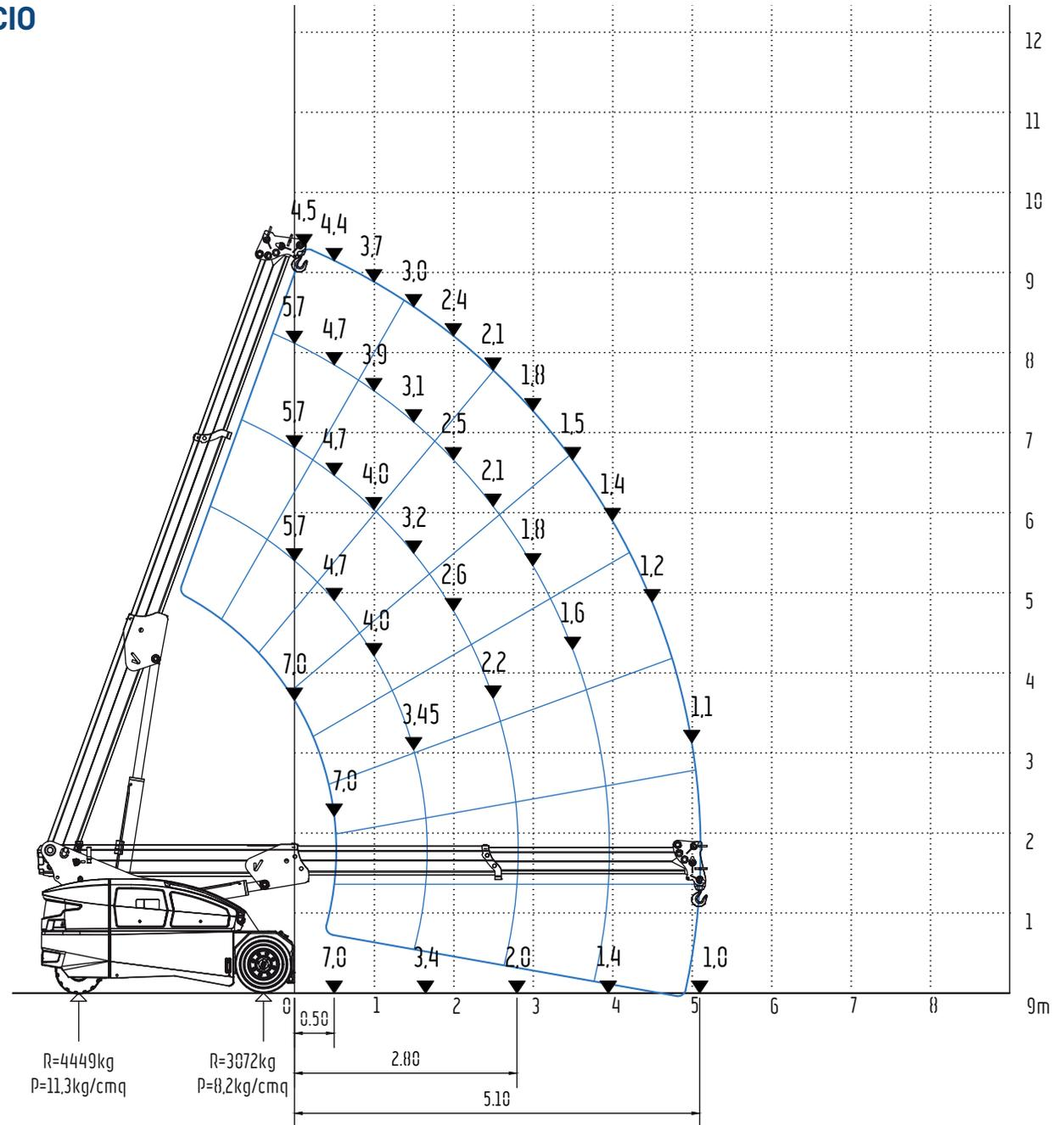

V70R

DIAGRAMMA DI PORTATA (t) - VERSIONE CON GANCIO

Load diagram (t) - Hook version

Tableau des charges utiles (t) - Version avec crochet

Traglastdiagramm (t) - Version mit Haken

Diagrama de las capacidades de carga (t) - Versión con gancho

cod. 188.361 Rev A

POS. 2

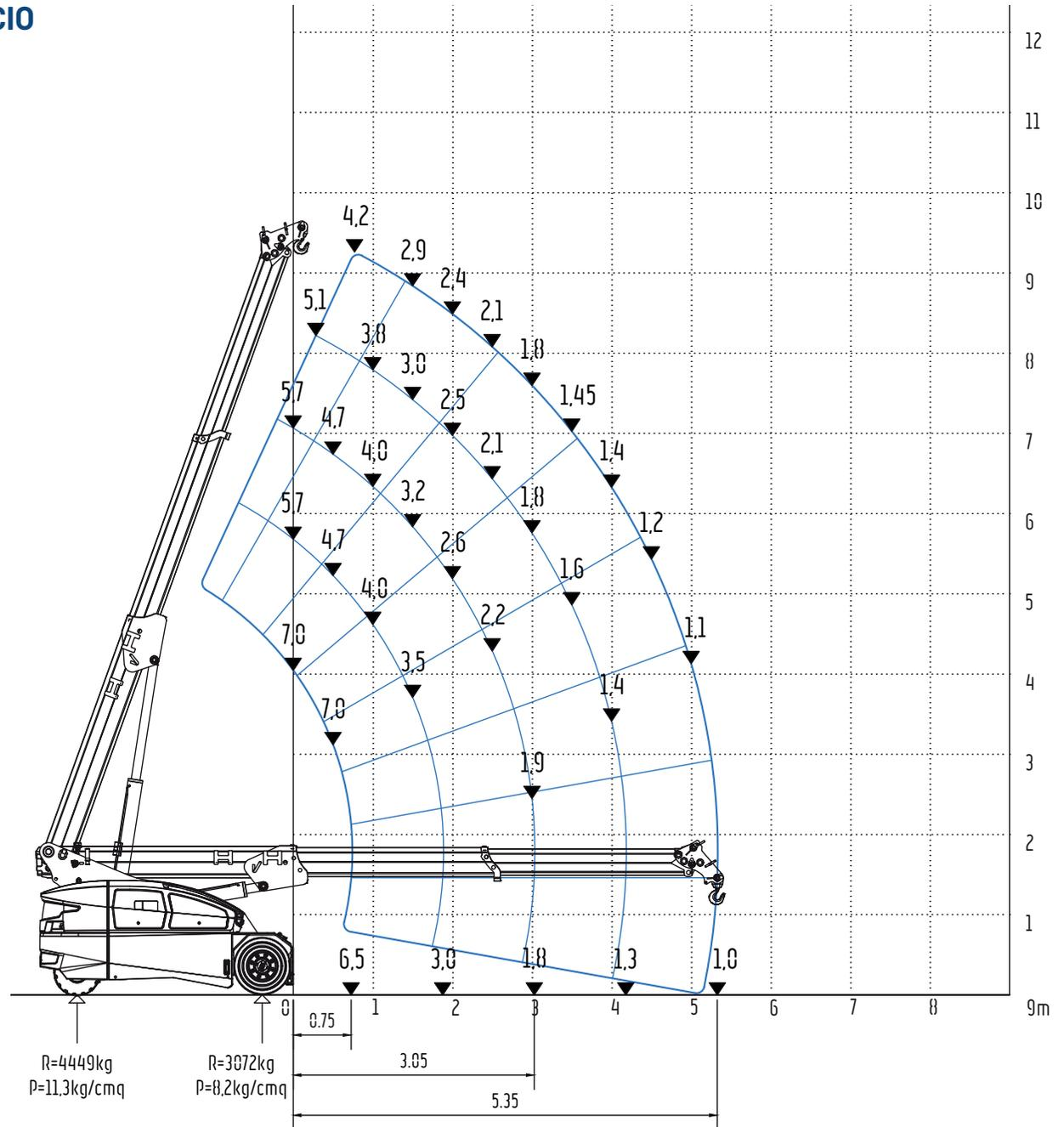

V70R

DIAGRAMMA DI PORTATA (t) - VERSIONE CON GANCIO

Load diagram (t) - Hook version

Tableau des charges utiles (t) - Version avec crochet

Traglastdiagramm (t) - Version mit Haken

Diagrama de las capacidades de carga (t) - Versión con gancho

cod. 188.361 Rev A

POS. 3

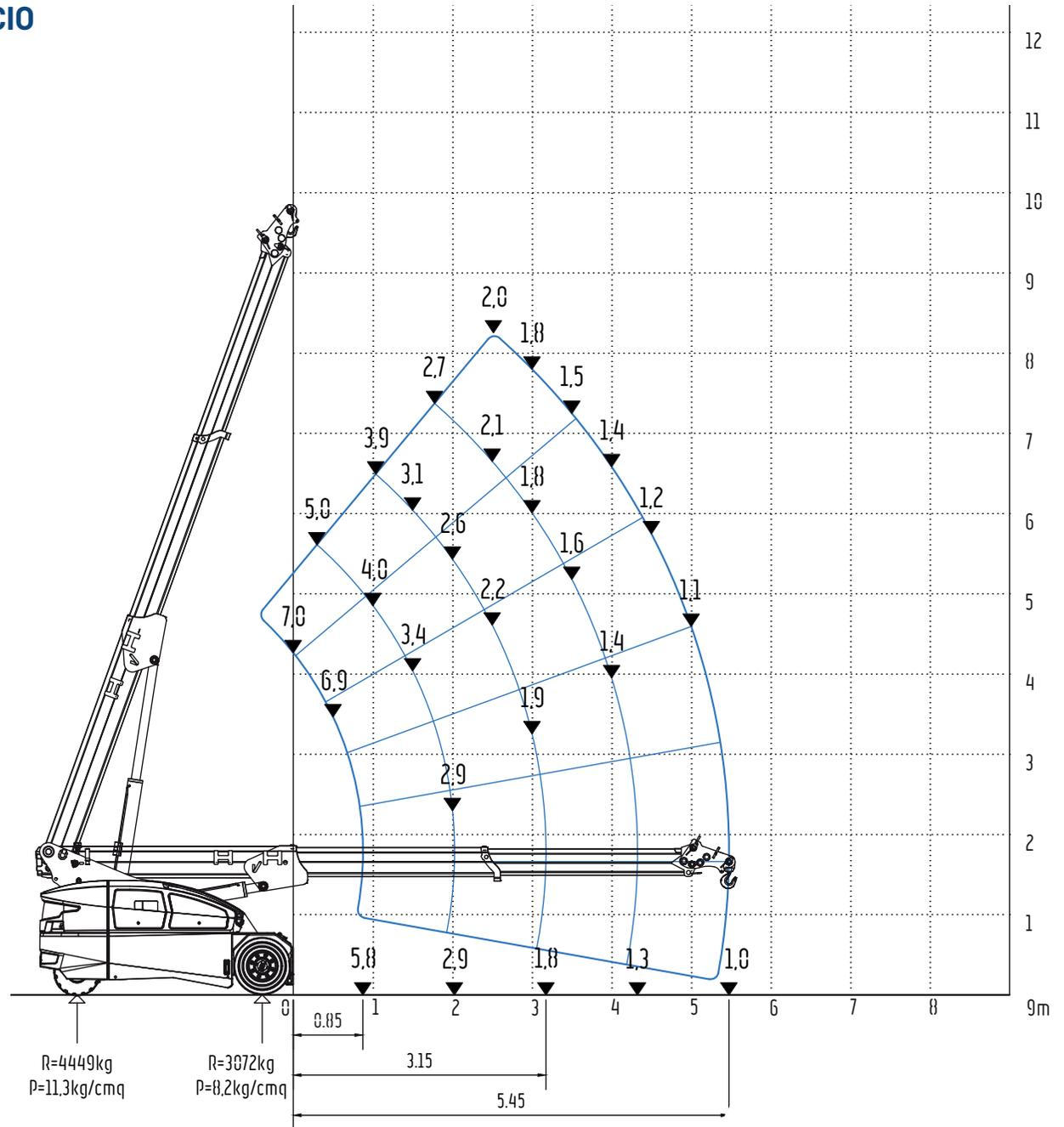

V70R

DIAGRAMMA DI PORTATA (t) - VERSIONE CON GANCIO

Load diagram (t) - Hook version

Tableau des charges utiles (t) - Version avec crochet

Traglastdiagramm (t) - Version mit Haken

Diagrama de las capacidades de carga (t) - Versión con gancho

cod. 188.361 Rev A

POS. 4

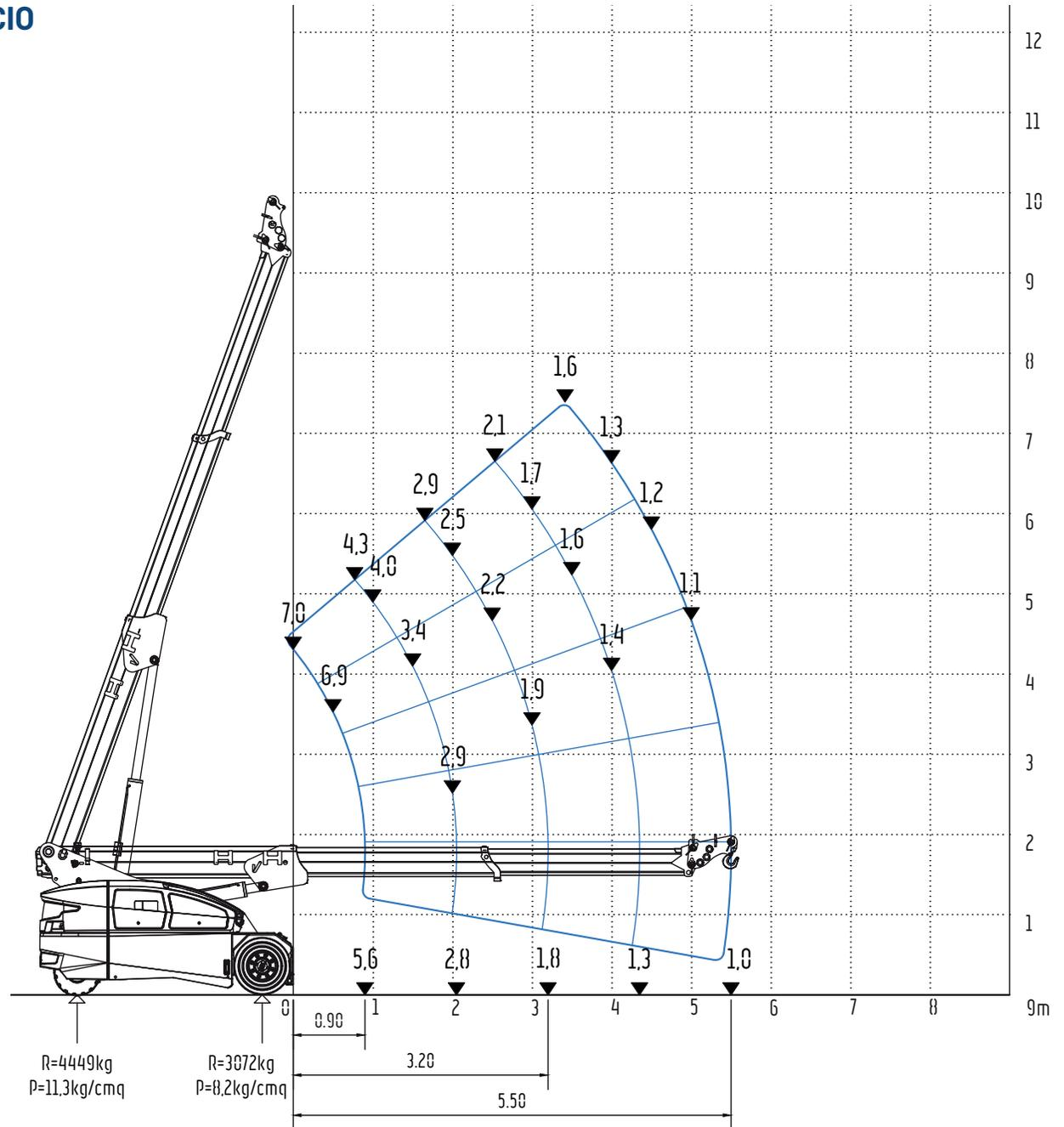

V70R

DIAGRAMMA DI PORTATA (t) VERSIONE CON GANCIO A ZERO ZAVORRE

Load diagram (t) - Hook version without counterweights
 Tableau des charges utiles (t) - Version avec crochet sans contrepoids
 Traglastdiagramm (t) - Version mit Haken ohne Gegengewichte
 Diagrama de las capacidades de carga (t) - Versión con gancho sin contrapesos

cod. 188.365 Rev A

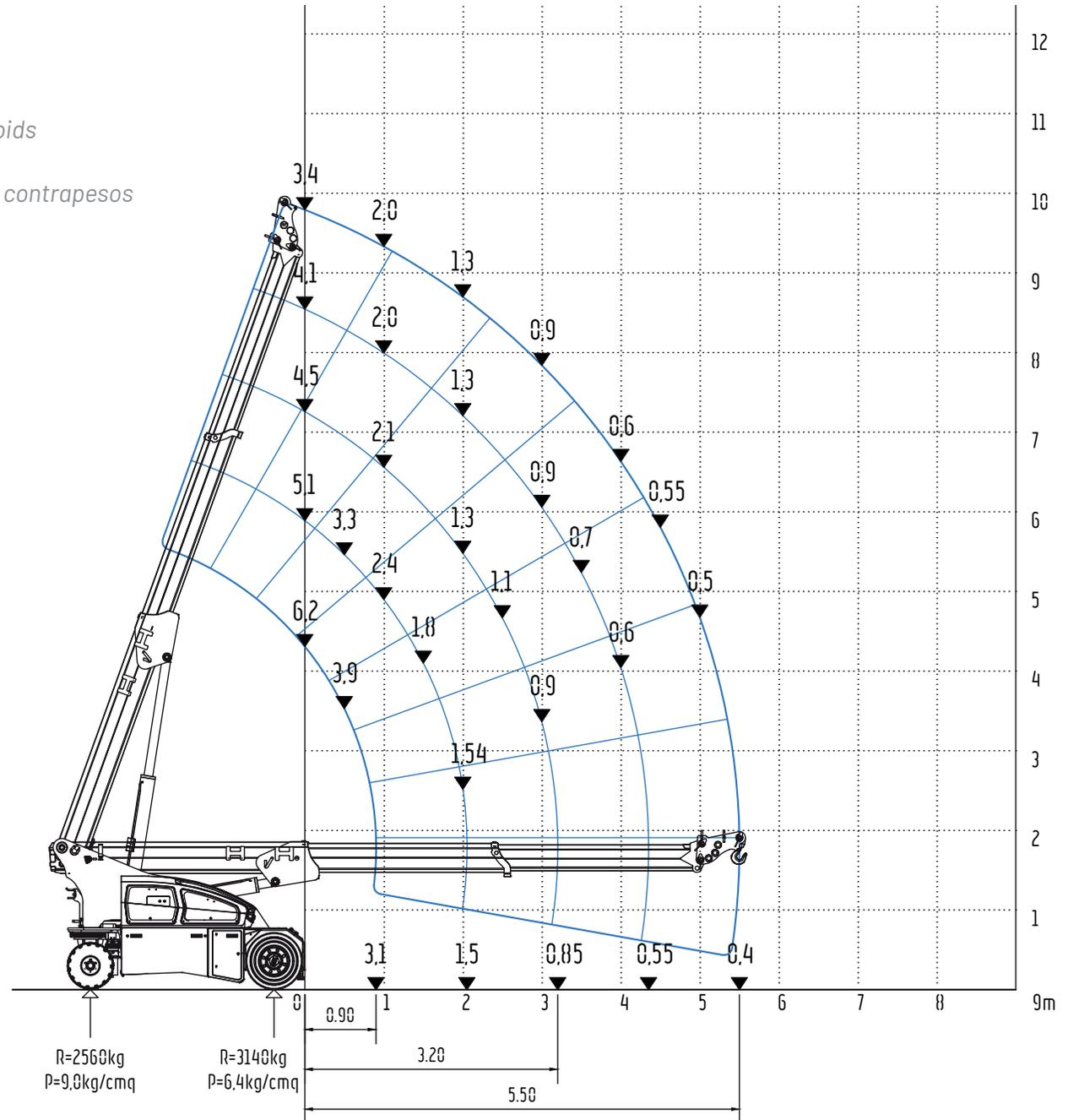

V70R

DIAGRAMMA DI PORTATA (t) VERSIONE CON JIB IDRAULICO RIPIEGABILE

Load diagram (t) - Foldable hydraulic jib version
 Tableau des charges utiles (t) - Version avec flechette hydraulique pliable
 Traglastdiagramm (t) - Version mit Klappbarer hydraulischer Ausleger
 Diagrama de las capacidades de carga (t) - Versión con pluma hidráulica plegable

cod. 188.363 Rev A

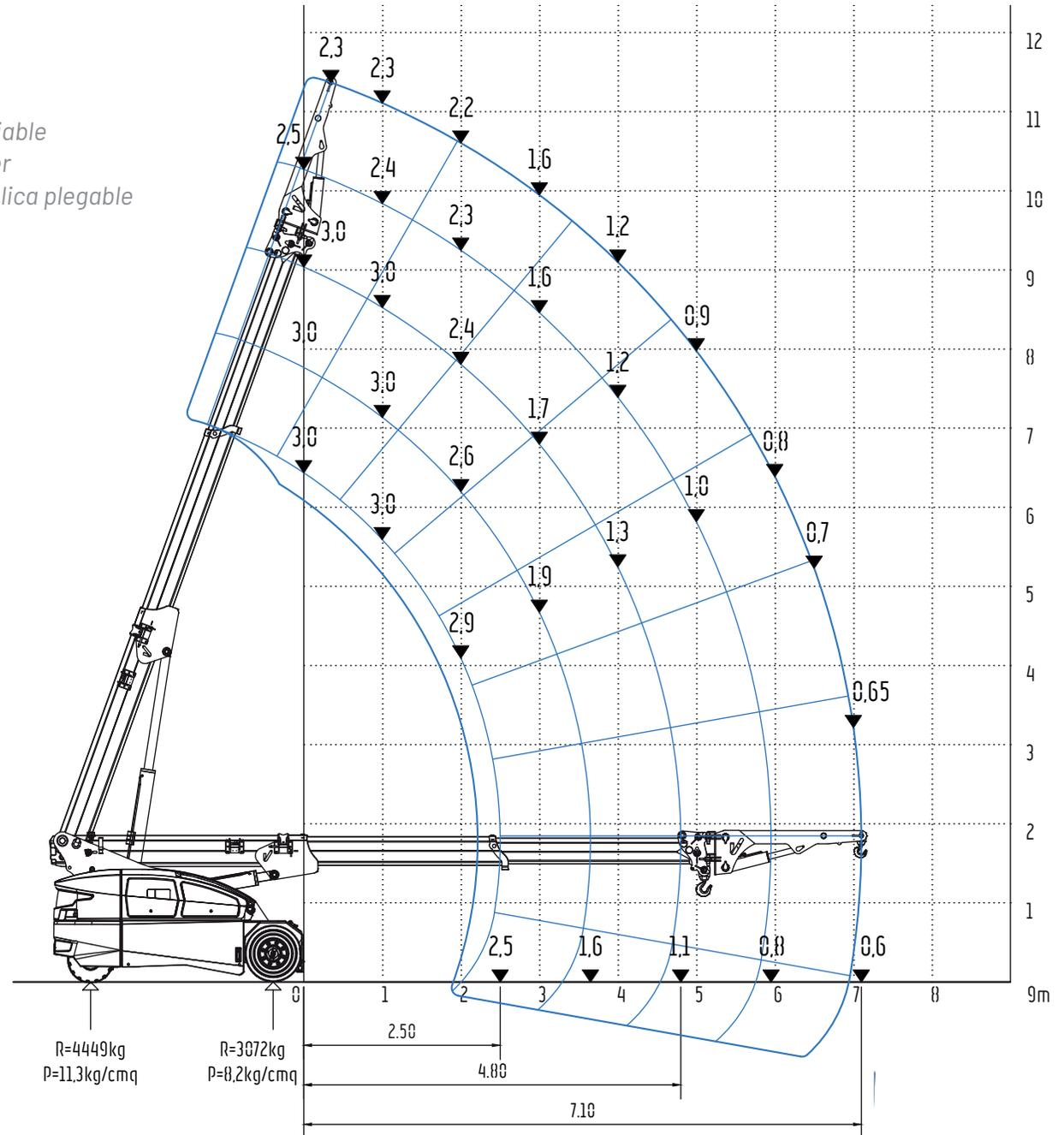

V70R

DIAGRAMMA DI PORTATA (t) - VERSIONE CON ARGANO

Load diagram (t) - Winch version

Tableau des charges utiles (t) - Version avec treuil

Traglastdiagramm (t) - Version mit Winde

Diagrama de las capacidades de carga (t) - Cabrestante versión

cod. 188.362 Rev A

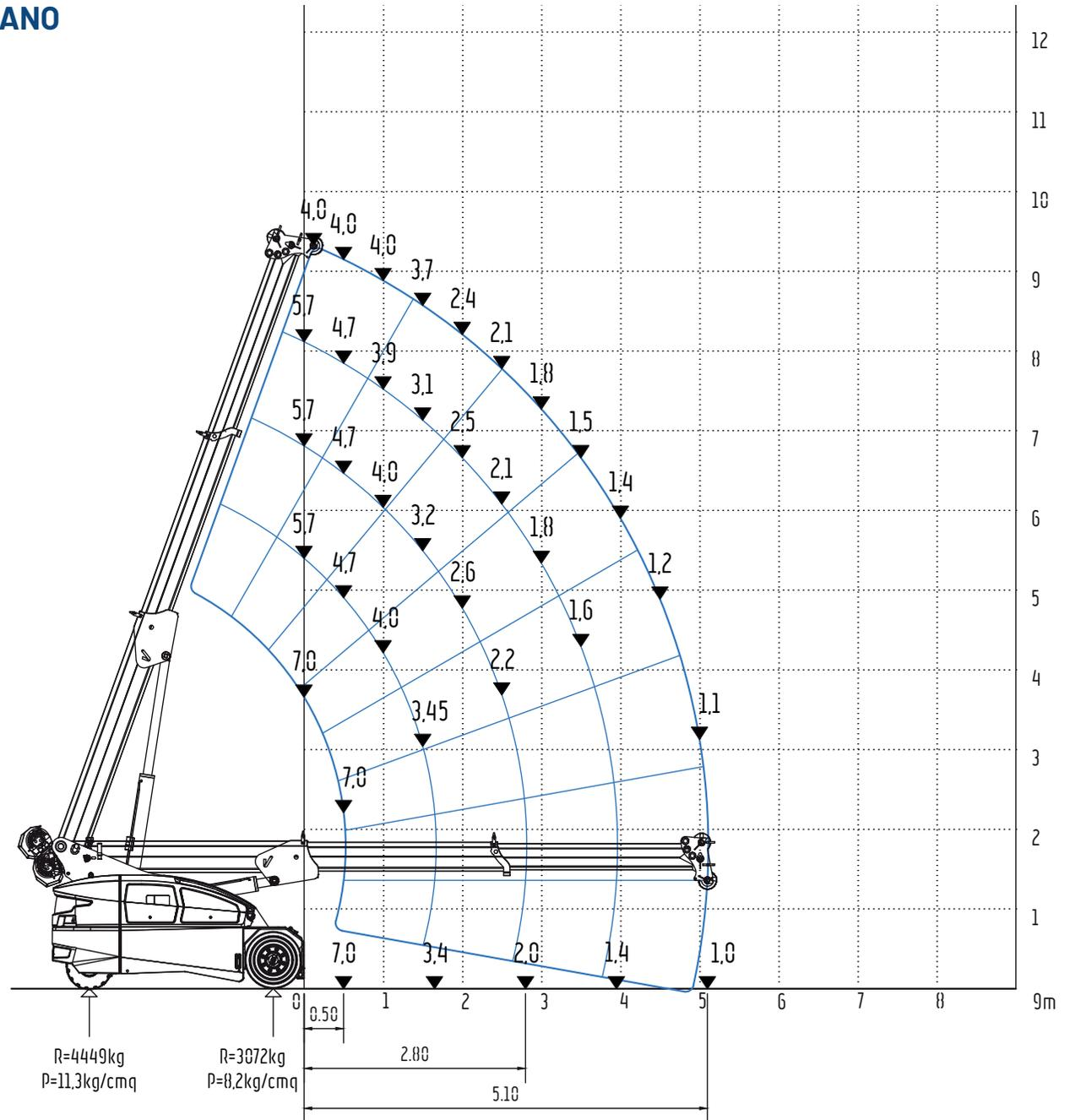

V70R

DIAGRAMMA DI PORTATA (t) VERSIONE CON ARGANO E JIB IDRAULICO RIPIEGABILE

Load diagram (t) - Winch and foldable hydraulic jib version
 Tableau des charges utiles (t) - Version avec treuil et flechette hydraulique pliable
 Traglastdiagramm (t) - Version mit Winde und Klappbarer hydraulischer Ausleger
 Diagrama de las capacidades de carga (t) - Versión con cabrestante y pluma hidráulica plegable

cod. 188.364 Rev A

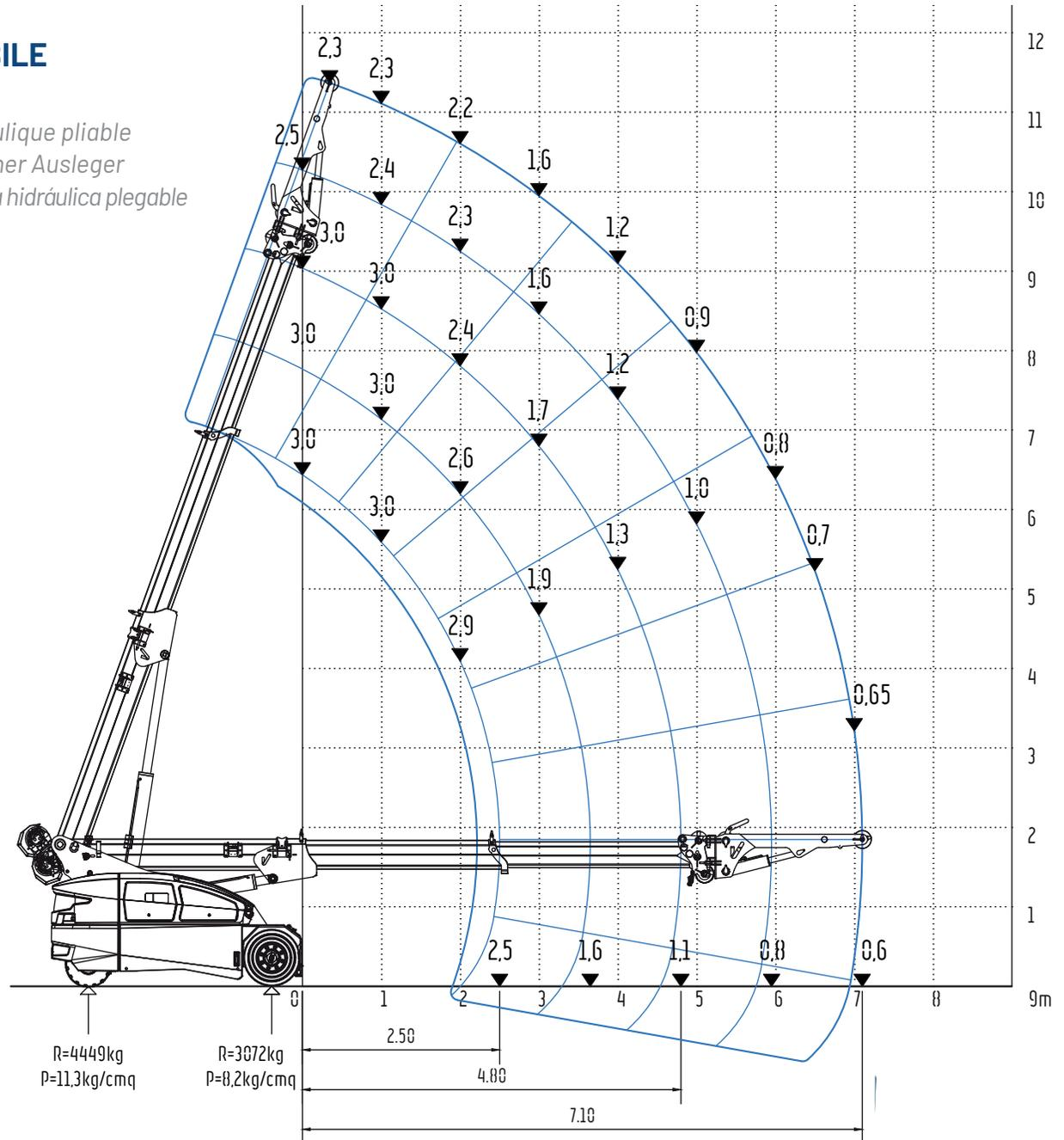

V70R

DIAGRAMMA DI PORTATA (t) VERSIONE CON ARGANO E JIB IDRAULICO RIPIEGABILE A ZERO ZAVORRE

Load diagram (t)
Winch and foldable hydraulic jib version without counterweights
Tableau des charges utiles (t)
Version avec treuil et flechette hydraulique pliable sans contrepoids
Traglastdiagramm (t)
Version mit Winde und Klappbarer hydraulischer Ausleger ohne Gegengewichte
Diagrama de las capacidades de carga (t)
Versión con cabrestante y pluma hidráulica plegable sin contrapesos

cod. 188.366 Rev A

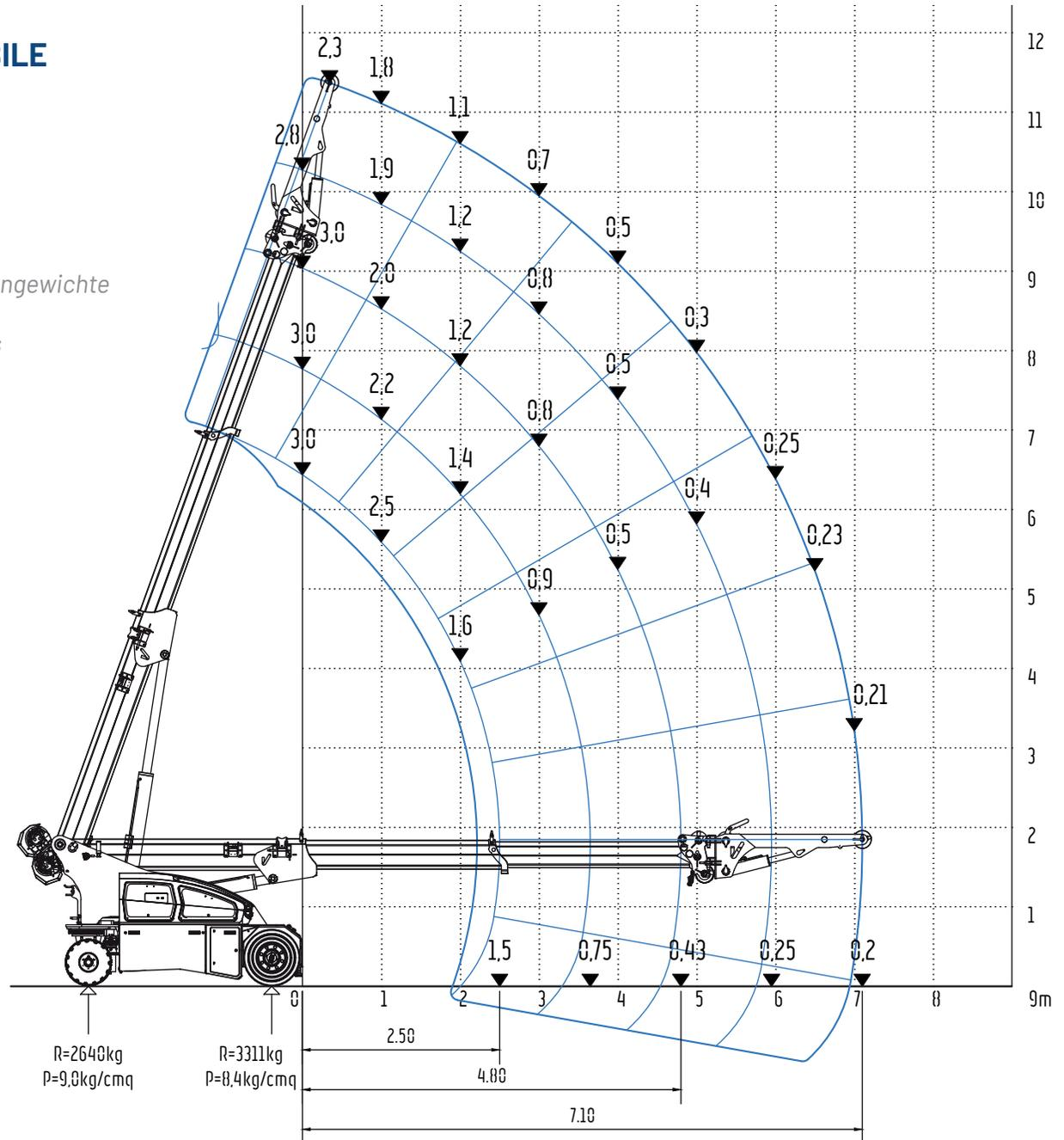

V70R

DIAGRAMMA DI PORTATA (t) - VERSIONE CON FORCHE

Load diagram (t) - Forks version

Tableau des charges utiles (t) - Version avec fourches

Traglastdiagramm (t) - Version mit Gabeln

Diagrama de las capacidades de carga (t) - Horquillas versión

cod. 188.367 Rev A

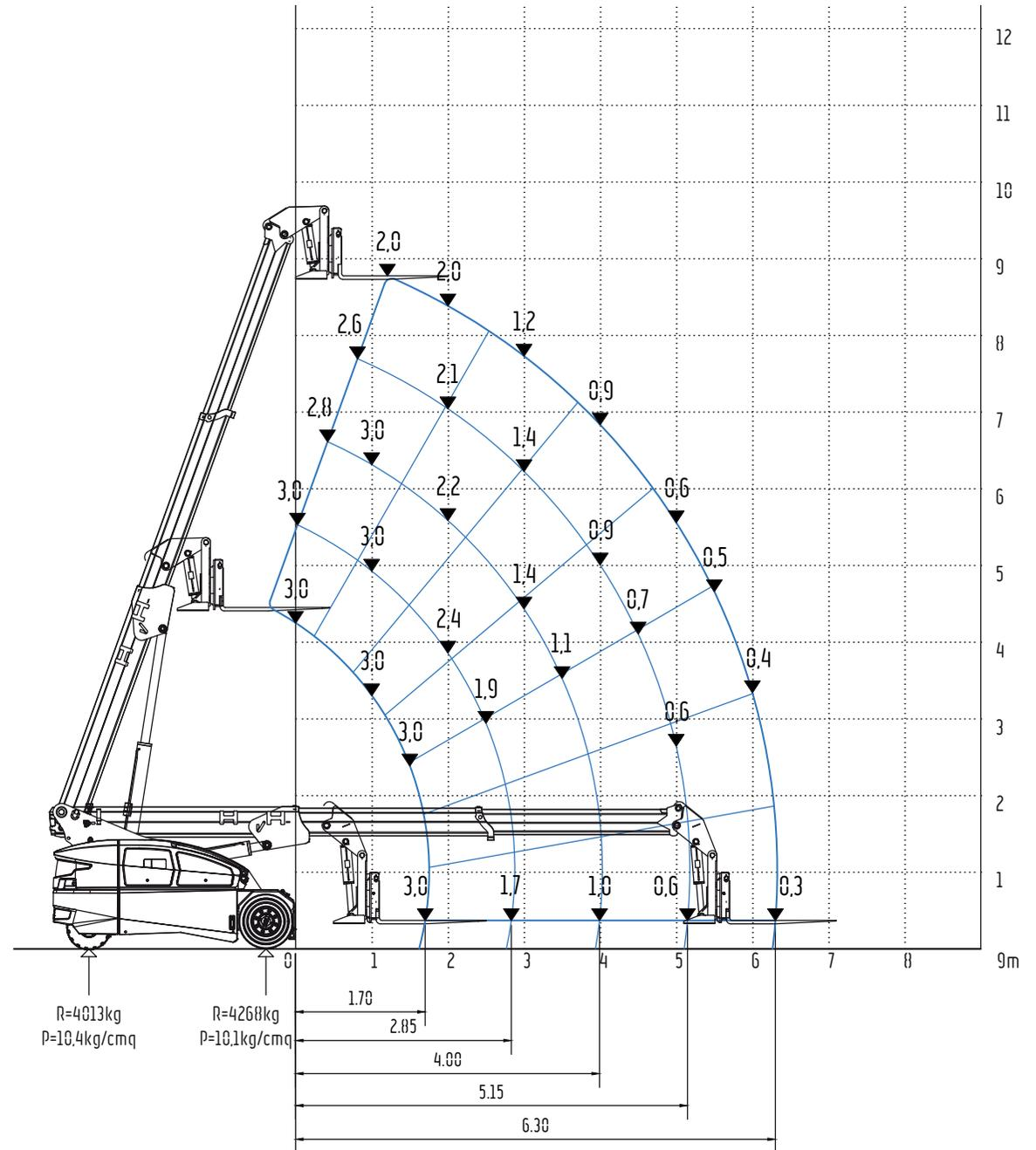



+44 (0)1482 481960

info@valla-cranes.co.uk

Northern

(Head Office)
English Street,
Hull HU3 2BS

Central

Shaw Lane Industrial Estate
Ogden Road, Doncaster
DN2 4SQ

Southern

Unit 8, Redhill 23 Business Park
Holmethorpe Avenue,
Redhill RH1 2NB



Valla is a brand of Manitex International

Dati tecnici e caratteristiche possono subire variazioni senza preavviso. Le macchine rappresentate potrebbero avere accessori opzionali. Le misure indicate nel documento possono avere una tolleranza del valore di +/-3%.

Technical data and features are subject to change without notice, machines shown may have optional accessories. The measurements indicated in the document may have a tolerance of +/-3%.

Les données techniques et les caractéristiques peuvent être modifiées sans préavis, les machines illustrées peuvent avoir des accessoires en option. Les mesures indiquées dans le document peuvent avoir une tolérance de +/-3%.

Eigenschaften und technische Daten können ohne Vorankündigung geändert werden.

Die angezeigten Maschinen könnten Sonderausstattungen haben. Die im Dokument angegebenen Maße können eine Toleranz von +/-3 % haben.

Los datos técnicos y las características están sujetos a cambios sin previo aviso, las máquinas que se muestran pueden tener accesorios opcionales. Las medidas indicadas en el documento pueden tener una tolerancia de +/-3%.